

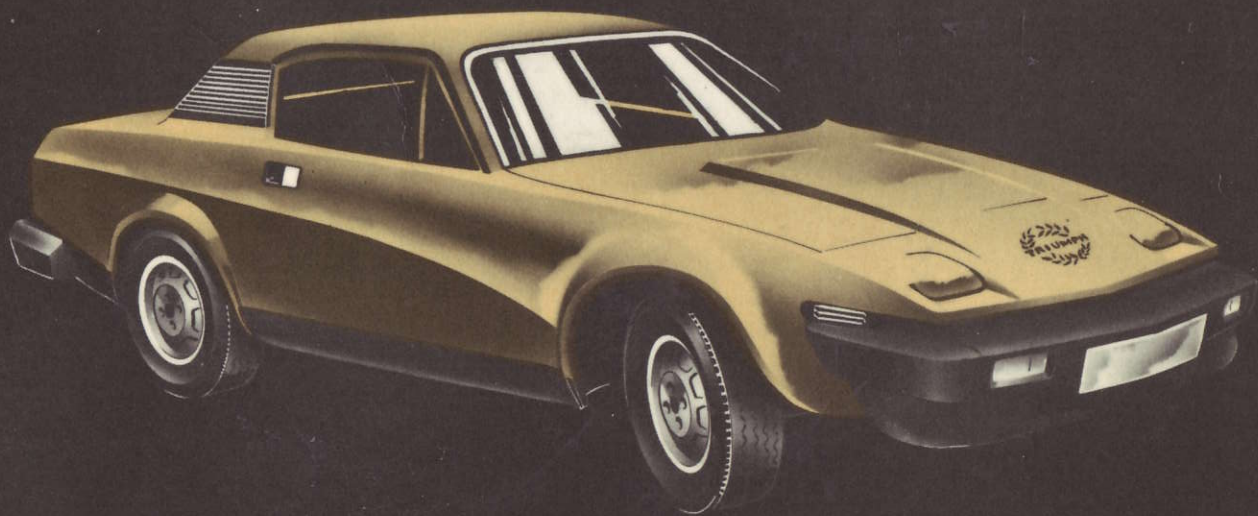

TR7





TR7



Published by
BL Cars Limited

Publication Part No. AKM 4152 Issue 3

JAGUAR ROVER TRIUMPH INC.
600 WILLOW TREE ROAD, LEONIA.
N.J. 07605

In all communications relating to Service or Spares, please quote the Commission Number (Chassis Number.) paint and trim numbers. These are stamped on a plate attached to the left-hand door rear closing face. The Commission Number is also stamped on a plate attached to the left-hand windscreen pillar and is visible through the screen.

When L.H. or R.H. is used in the text, this refers to the Left-hand or Right-hand of the vehicle, viewed from the driver's seat.

The Manufacturers reserve the right to vary their specifications with or without notice, and at such times and in such manner as they think fit. Major as well as minor changes may be involved in accordance with the Manufacturer's policy of constant product improvement.

Whilst every effort is made to ensure the accuracy of particulars contained in this Handbook, neither The Manufacturer nor the Dealer, by whom this Handbook is supplied, shall in any circumstances be held liable for any inaccuracy or the consequences thereof.

All rights reserved. No part of this publication may be reproduced, stored in a retrieval system or transmitted in any form, electronic, mechanical, photocopying, recording or any other means without prior written permission from the Service Division of BL Cars Limited.

CONTENTS

Introduction	5
Controls, Instruments and Indicators	7
Body Fittings	17
Seats and Safety Harness	25
Heating, Ventilation and Air Conditioning	29
Running Instructions	33
Towing a Caravan or Trailer	39
Automatic Transmission	43
Wheels and Tyres	47
Cooling System	51
Electrical System	55
Care of Bodywork	65

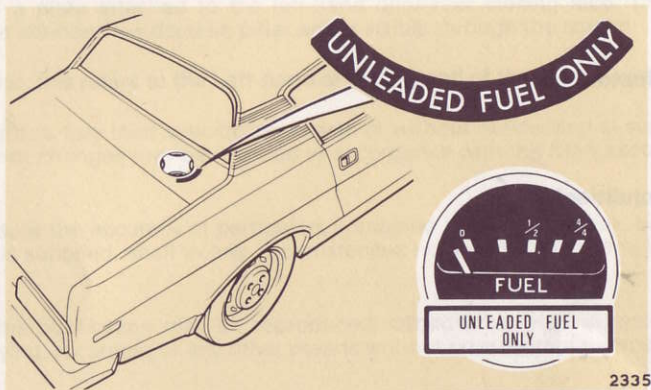

**IMPORTANT
CATALYTIC CONVERTER SPECIFICATION VEHICLES ONLY**

The TR7 (Catalytic Converter Specification) is designed to operate on UNLEADED fuels of 91 octane.

It is essential that only unleaded fuels are used in this vehicle otherwise serious damage can be caused to the Catalytic Converter.

**IMPORTANT
CANADA SPECIFICATION**

The TR7-CANADA, which is not fitted with a Catalytic Converter, performs efficiently on fuels of 91 octane (Regular Fuel). The engine is designed to use either leaded or unleaded fuel.

INTRODUCTION

Now that you have taken delivery of your new car, please read this Handbook carefully to familiarize yourself with the controls and other features, which have been designed for your safety and comfort.

The lock key number is stamped on the tag attached to the larger key of your key-set, and is not shown on the key or lock.

Please make a record of this number as you will need it to obtain a replacement.

Servicing

Before receiving your new car it will have undergone an inspection to ensure that all systems are working and the vehicle is complete to specification.

After completing 1000 miles the vehicle should be returned to the selling Dealer who will carry out the first important service and make whatever adjustments are required, free of charge except for cost of lubricants.

Subsequent to the free service, maintenance and servicing of the vehicle is the responsibility of the owner who is advised to make full use of the planned maintenance operated by all Jaguar Rover-Triumph franchise holders. The operations carried out by your Dealer will be in accordance with current recommendations and may be subject to revision from time to time.

The 'Passport to Service' which includes the 'Owners Service Statement' has provision for the Dealer to certify that the work has been performed in accordance with current recommendations. Regular use of the 'Passport to Service' at the specified intervals is the best safeguard against the possibility of abnormal repair bills at a later date and would constitute proof of regular servicing, thus enhancing the value of your car to a prospective buyer.

Jaguar-Rover-Triumph Dealers are provided with the latest information concerning special tools and workshop techniques, enabling them to undertake your service and repairs in the most efficient and economic manner.

Before entering the vehicle :-

- Check that the windows are clean and visibility is not impaired.
- Check that light lenses are clean.
- Check tyres for condition and correct pressure.
- Check that the area around the car is clear of driving hazards, before driving off.
- Check that the bonnet and boot are securely closed.

On entering the vehicle :-

- Adjust the seats and head restraints.
- Adjust the interior and exterior (Door) mirrors.
- Fasten seat belts, ensure that passengers do likewise.
- Check the operation of light switches, horn and hazard warning.
- With the ignition switched on, check the operation of all warning lights.

CONTROLS, INSTRUMENTS AND INDICATORS

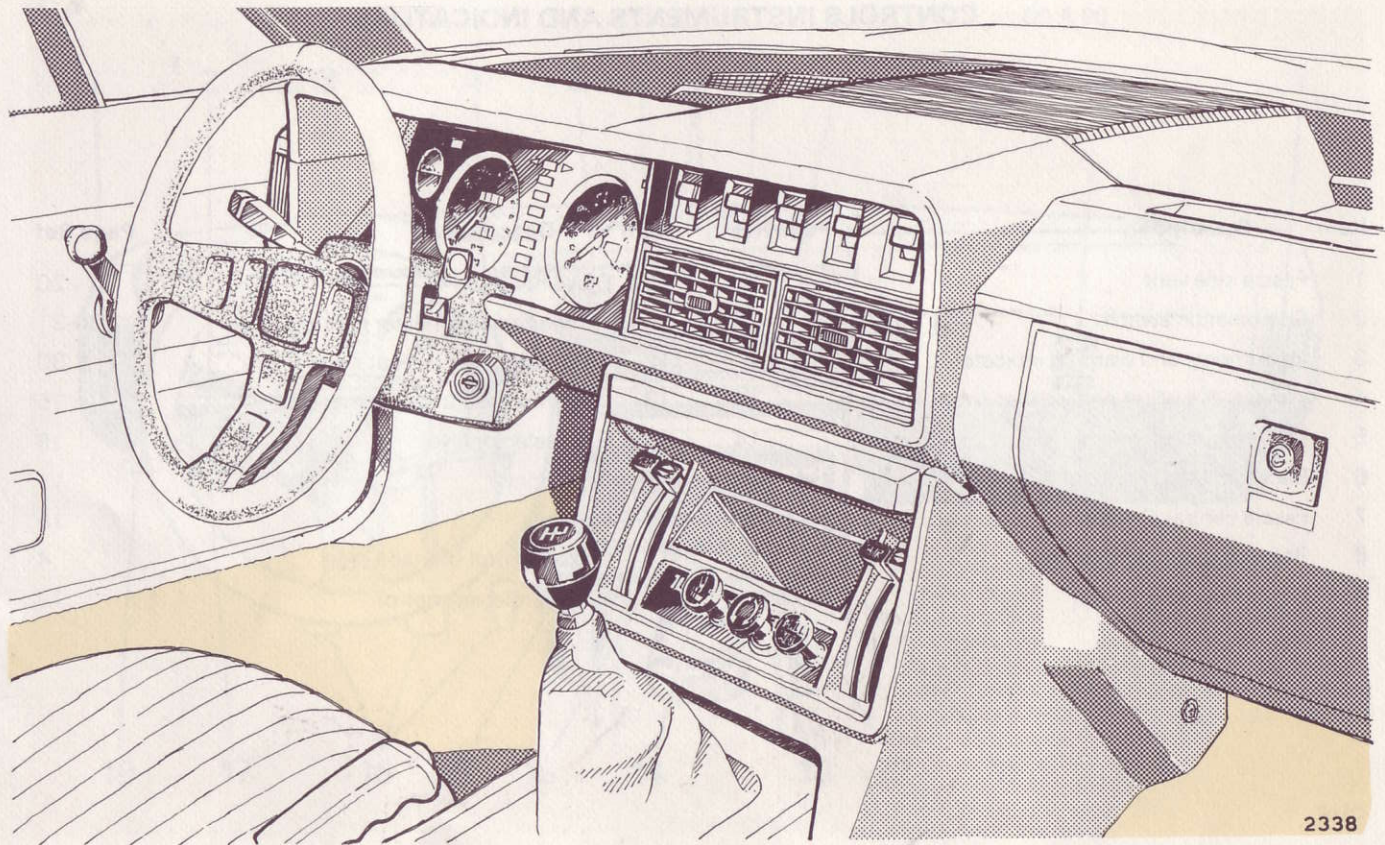

2338

CONTROLS, INSTRUMENTS AND INDICATORS

02 A 00 CONTROLS INSTRUMENTS AND INDICATORS

Item	Description	Page Ref	Item	Description	Page Ref
1	Fascia side vent	32	10	Glove box lock	20
2	Combination switch	13	11	Air conditioning/heater controls	30-31
3	Instruments and warning indicators	11	12	Air conditioning cut-out switch	30
4	Windscreen wiper and washer control	14	13	Instrument illumination rheostat	15
5	Master lighting switch	14	14	Gear selector lever	16
6	Backlight heater switch	15	15	Cigar lighter	15
7	Fascia central air vent	32	16	Pedals	16
8	Rear fog guard lamp switch	15	17	Choke control (Canada only)	4
9	Hazard warning switch	15	18	Bonnet release control	19

CONTROLS, INSTRUMENTS AND INDICATORS

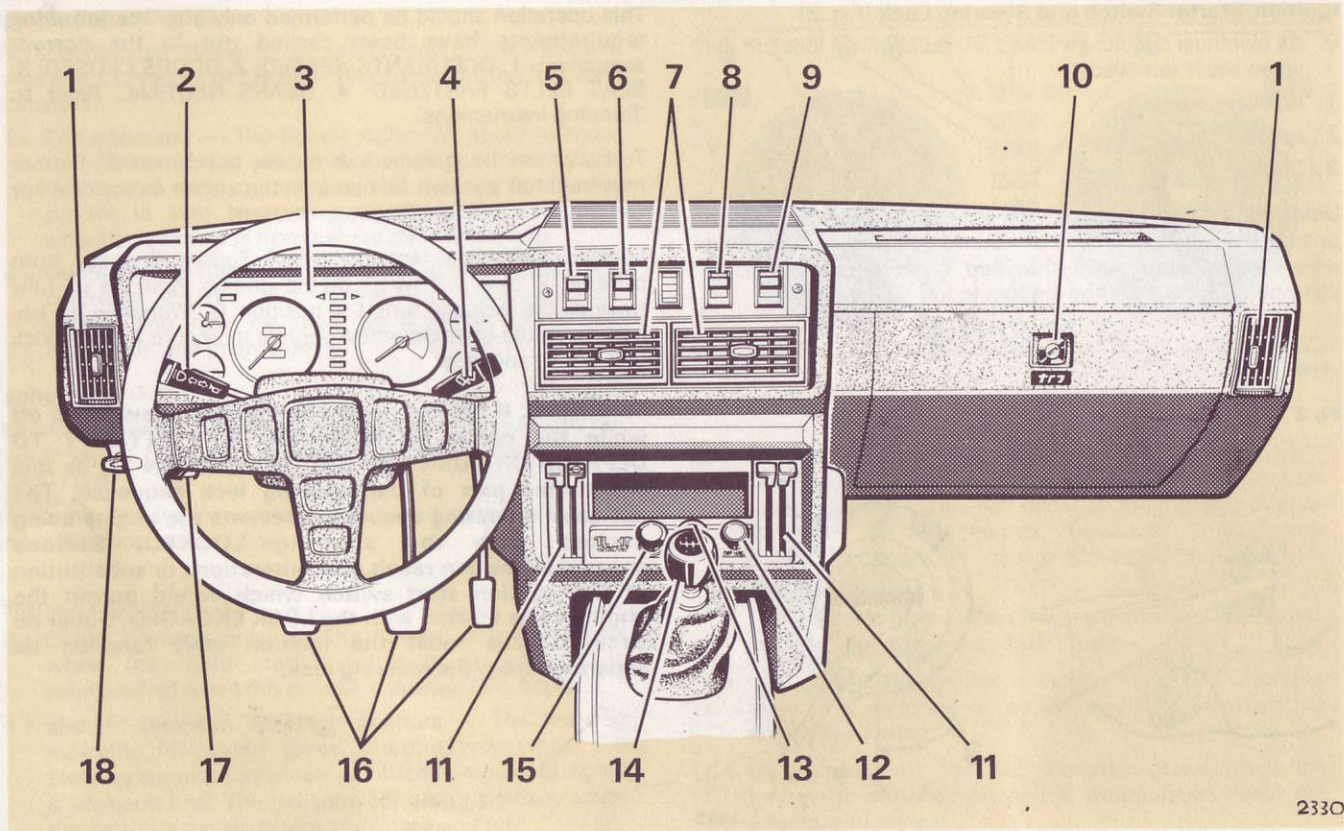

2330

CONTROLS, INSTRUMENTS AND INDICATORS

Ignition/Starter Switch and Steering Lock (Fig. 2)

0. All electrical circuits switched off: mechanical lock pre-set when key is removed.
1. Auxiliary position.
2. Ignition.
3. Start.

Unlocking Sequence (clockwise) Insert the key and turn it to position '1'. If difficulty is encountered, turn the steering wheel slightly to relieve the load on the lock bolt. The steering wheel should now be free to turn.

This operation should be performed only after the following requirements have been carried out in the correct sequence:- 1. OCCUPANTS SEATED; 2. DOORS CLOSED; 3. SEAT BELTS FASTENED; 4. GEARS NEUTRAL. Refer to 'Running Instructions'.

To switch on the ignition, turn the key to position '2'. Further movement to position '3' operates the starter motor. The key will return to position '2' when released.

Locking Sequence (anti-clockwise) Turning the key from position '2' to '1' will switch off the ignition. Push the key fully towards the lock and turn it to position '0'. Withdraw the key and move the steering wheel slightly to ensure that the lock bolt is fully engaged.

WARNING. If for any reason the ignition is switched off while the car is in motion **DO NOT ATTEMPT TO DEPRESS OR TURN THE KEY TO POSITION '0'**, as this constitutes part of the steering lock sequence. The designed operating sequence prevents the engine being started with the steering **LOCKED**. Serious consequences can result from alterations or substitution of the ignition start switch which would permit the engine to be started with the **LOCK ENGAGED**. Under no circumstances must the ignition start function be separated from the steering lock.

Fig. 2

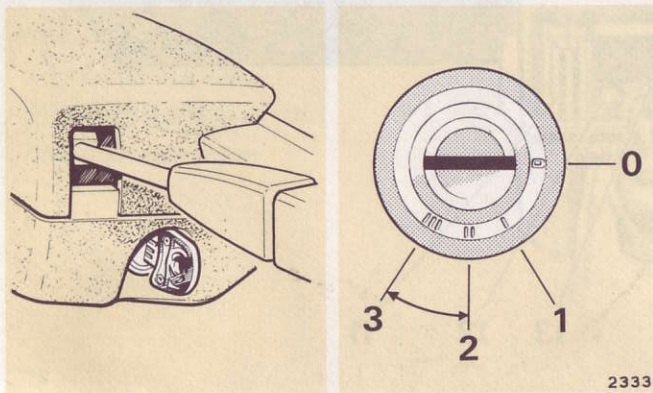

CONTROLS, INSTRUMENTS AND INDICATORS

Fig. 3

Speedometer (Fig. 3)

The speedometer indicates the road speed of the vehicle in miles and kilometres per hour. It also combines the following indicators:

- (1) **Trip odometer** — The figures within the aperture above the centre of the dial may be used to record the distance of each journey provided that the figures are pre-set to zero by turning clockwise the knob that extends downwards from behind the instruments.
- (2) **Odometer** — The figure within the aperture below the centre of the dial records the total mileage of the vehicle and may be used as a guide to periodic lubrication and maintenance.

Tachometer (Fig. 3)

The tachometer indicates the engine speed in revolutions per minute and is calibrated in increments of 500, extending to 7,000 r.p.m.

Recommendations concerning the speed range are given under 'Running Instructions'.

Warning Lights (Fig. 3)

- (3) **Choke (Canada only)** — The 'Choke' indicator glows when the 'cold start' control is pulled and is extinguished when the control is pushed fully home.
- (4) and (5) **Direction indicator monitors** — The arrowed indicator (4) glows green intermittently when the steering column combination switch is moved to signal a left-hand turn. The indicator (5) glows similarly when the switch is moved to signal a right-hand turn.

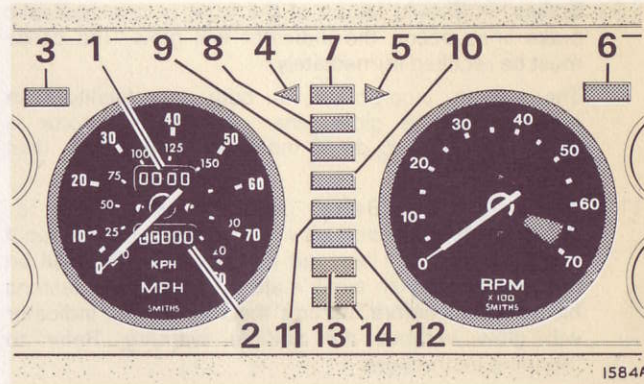

(6) Oxygen Sensor (PI vehicles only)

The Oxygen Sensor indicator glows when the sensors require renewal. This will occur at the mileage interval stated in the Maintenance Handbook. Consult your dealer as soon as convenient after the indicator illuminates.

The indicator glows when the starter motor is operated, failure to do so indicates bulb failure.

(7) Ignition — The 'Ignition' indicator glows red when the ignition is switched on and is extinguished when the engine is running.

(8) Oil pressure — The 'Oil' indicator glows when the ignition is switched on and is extinguished when the engine is running.

CONTROLS, INSTRUMENTS AND INDICATORS

- (9) **Brakes** — Should failure of the front or rear hydraulic brake lines occur, the indicator will glow. The cause must be rectified immediately.

The system incorporates a bulb test facility. The indicator should glow when the starter motor is operated, failure to do so indicates a faulty bulb. (Not P.I.).

- (10) **Belts** — The 'Belts' indicator will glow for approximately ten seconds when the engine is started if the driver has not fastened his seat belt. This will be accompanied by an audible alarm. If the driver fastens his seat belt before starting the engine, the indicator will glow without the audible warning. Refer to 'Running Instructions'.

Fig. 4

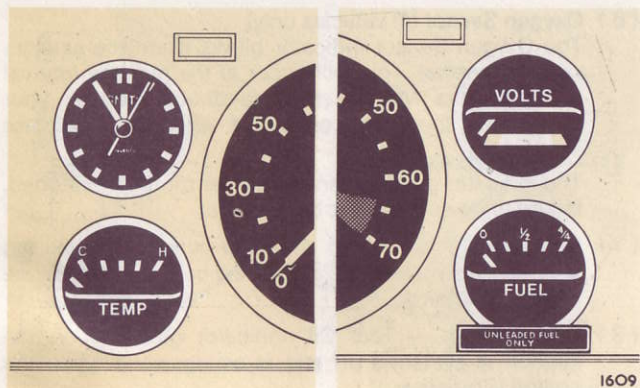

- (11) **Park Brake** — The park brake indicator glows when the handbrake is applied and the ignition is switched on.

- (12) **Coolant** — The 'Coolant' indicator glows when the coolant level in the header tank is too low. The fault should be rectified immediately by topping up the header tank to the recommended instruction (page 53). A prudent watch should be kept on the coolant temperature gauge to ensure that the engine does not overheat.

The indicator glows for three seconds when the ignition is switched on, failure to do so indicates bulb failure.

- (13) **Main beam** — The 'Beam' indicator glows blue when main beams are selected and is extinguished during dipped beam operation.

- (14) **Fuel** — The Fuel indicator glows when the quantity of fuel in the tank falls below 6.8 litres (1.5 gallons). Fuel surge may cause the indicator to glow intermittently before the fuel is reduced to this amount.

Clock (Fig. 4)

The hands of the electrically operated clock can be reset by turning the knob located below the instrument and extending from the lower fascia rail.

Water Temperature Indicator (Fig. 4)

The gauge is marked 'C' (cold) and 'H' (hot), indicating the temperature of the coolant as it leaves the cylinder head. It is effective when the ignition is switched on.

When the ignition is switched off the needle should return to zero.

Fuel Gauge

The gauge indicates the contents of the fuel tank. Allow thirty seconds for the gauge needle to reach a steady reading after switching on the ignition.

When the ignition is switched off the needle should return to zero.

Voltmeter (Fig. 4)

The voltmeter registers the battery's state of charge. Under all normal running conditions the needle should register approximately midway along the scale. If the needle registers within the area at either extremity of the scale the battery or charging system needs attention.

Combination Switch (Fig. 5)

The steering-column combination switch serves the following purposes:

Horns — To operate the horns, press the end of the control.

Direction indicators — To indicate a left-hand turn, move the lever anti-clockwise. Move it clockwise for a right-hand turn. This control is only effective when the ignition is switched on.

Headlamp main beam — To operate the main beams, push the lever fully forward away from the steering wheel. Pull the lever to its neutral (central) position for dipped beams. This control is only effective when the 'master lighting switch' is moved to the headlamp position.

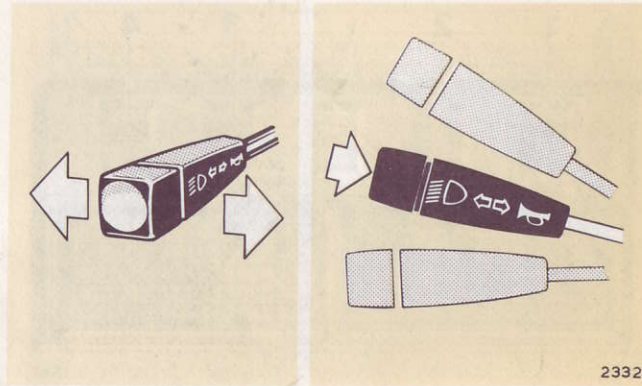

CONTROLS, INSTRUMENTS AND INDICATORS

Fig. 6

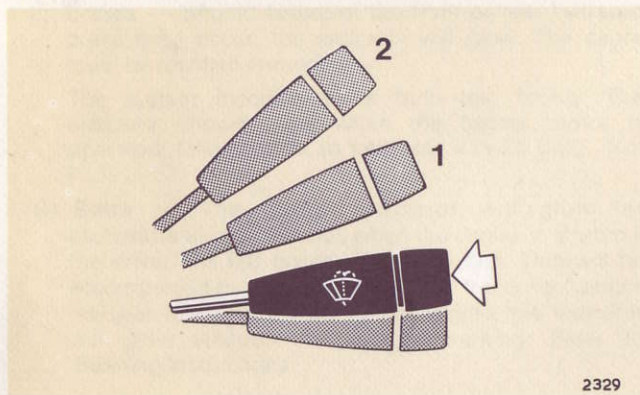
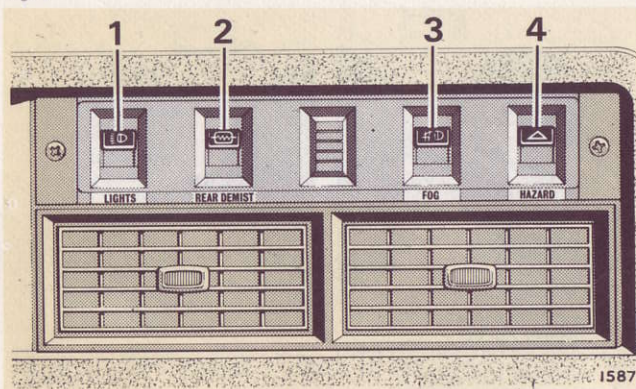

Fig. 7



Windscreen Wiper and Washer Control (Fig. 6)

The control is effective only when the ignition is switched on.

For continuous operation of the two speed wipers, move the control upwards to position '1' for slow-speed operation, or fully upwards to position '2' for high-speed operation. For brief use of the wiper, move the control downwards against spring pressure. Wiping will cease when the control is released.

To operate the windscreen washer, press the knob on the end of the control.

Master Lighting Switch (1, Fig. 7)

To operate the three-position lighting switch:

- Move the switch bar to the upper position to extinguish all external and fascia lamps.
- Move the switch bar to the mid position to illuminate front and rear parking and marker lamps and the fascia lamps.
- Move the switch bar to the lower position to raise and illuminate the headlamps and illuminate the parking, marker and fascia lamps.

If the headlamp lift mechanism fails to raise the headlamps, refer to 'Electrical System' — Headlamps.

CONTROLS, INSTRUMENTS AND INDICATORS

Heated Rear Screen Switch (2, Fig. 7)

Move the switch bar to the lower position to operate the heated rear screen, which will operate only when the ignition is switched 'ON'.

A lamp incorporated in the switch will illuminate while the heater is operating.

Do not leave switched 'ON' for longer than is necessary because of heavy current consumption.

To switch 'OFF' move the switch bar to the upper position.

The heater should not be used to remove snow or ice, but may be used periodically to remove condensation or to prevent ice formation.

Fog Lamp Switch (Optional fitment) (3, Fig. 7)

Move the switch bar to the mid position to illuminate the rear fog guard lamps only.

Move the switch bar to the lower position to illuminate the front and rear fog lamps.

Move the switch bar to the upper position to extinguish the lamps.

A warning lamp incorporated in the switch will illuminate while the lamp circuit is switched 'ON'.

Hazard Warning Switch (4, Fig. 7)

If the vehicle is immobilized and constitutes a hazard to other road users, warning may be given by using the 'hazard warning system'. To operate move the switch bar to the lower position.

Instrument Illumination Rheostat (1, Fig. 8)

From the 'off' position (fully anti-clockwise), turn the switch knob clockwise to illuminate the instruments at high intensity, and further clockwise to diminish the intensity.

See 'Master Lighting Switch'.

Cigar-lighter (2, Fig. 8)

The cigar-lighter is operated by pushing its knob inwards to heat the element. When a predetermined temperature is reached, the element is ejected from the 'heat' position from whence it may be withdrawn for use. A small pilot lamp is incorporated within the element carrier to facilitate replacement of the element during darkness.

Fig. 8

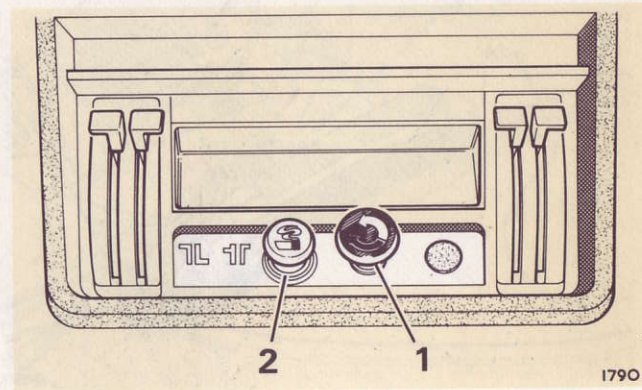

CONTROLS, INSTRUMENTS AND INDICATORS

Fig. 9

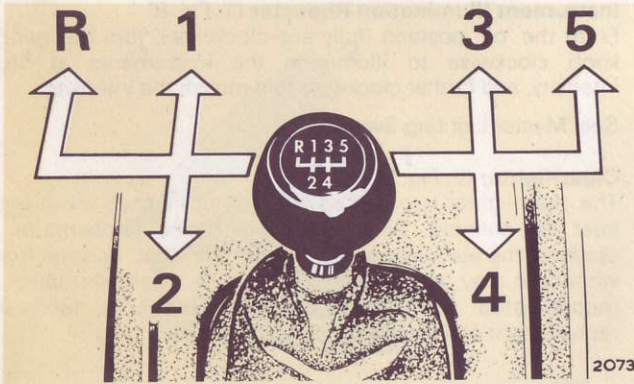

Gear Selector Lever (Fig. 9)

The gear positions are indicated on the lever knob. Engage reverse only when the vehicle is stationary.

Automatic transmission selector details are given in section — 'Borg-Warner Automatic Transmission'.

For optimum fuel economy the recommended gear change speeds are:

1st/2nd - 15 m.p.h.

2nd/3rd - 25 m.p.h.

3rd/4th - 40 m.p.h.

4th/5th - 45 m.p.h.

Fig. 10

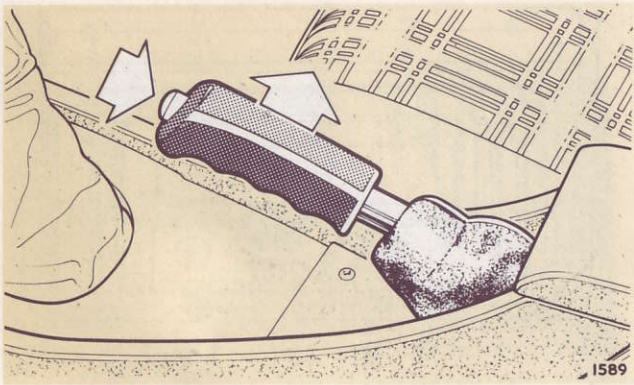

Handbrake Lever (Fig. 10)

To apply the rear wheel brakes, pull the handbrake lever upwards; it is retained by a ratchet and pawl. Release the hand brake by pulling it slightly upwards as the button is depressed to free the pawl; then allow the lever to move downwards to the off position.

Refer to 'Warning Lights' — page 11.

Pedals

The pedals are arranged in the conventional positions. The brake pedal operates the brake hydraulic system to apply the brakes on all four wheels. Warning lights at the rear of the vehicle function automatically when the brake pedal is pressed while the ignition is switched on. To avoid needless wear of the clutch withdrawal mechanism, do not rest the foot on the clutch pedal while driving.

Always remember to lock your car when leaving it.

The lock key number is stamped on the tag attached to the larger key of your key-set, and is not shown on the key or lock.

Please make a record of this number as you will need it to obtain a replacement.

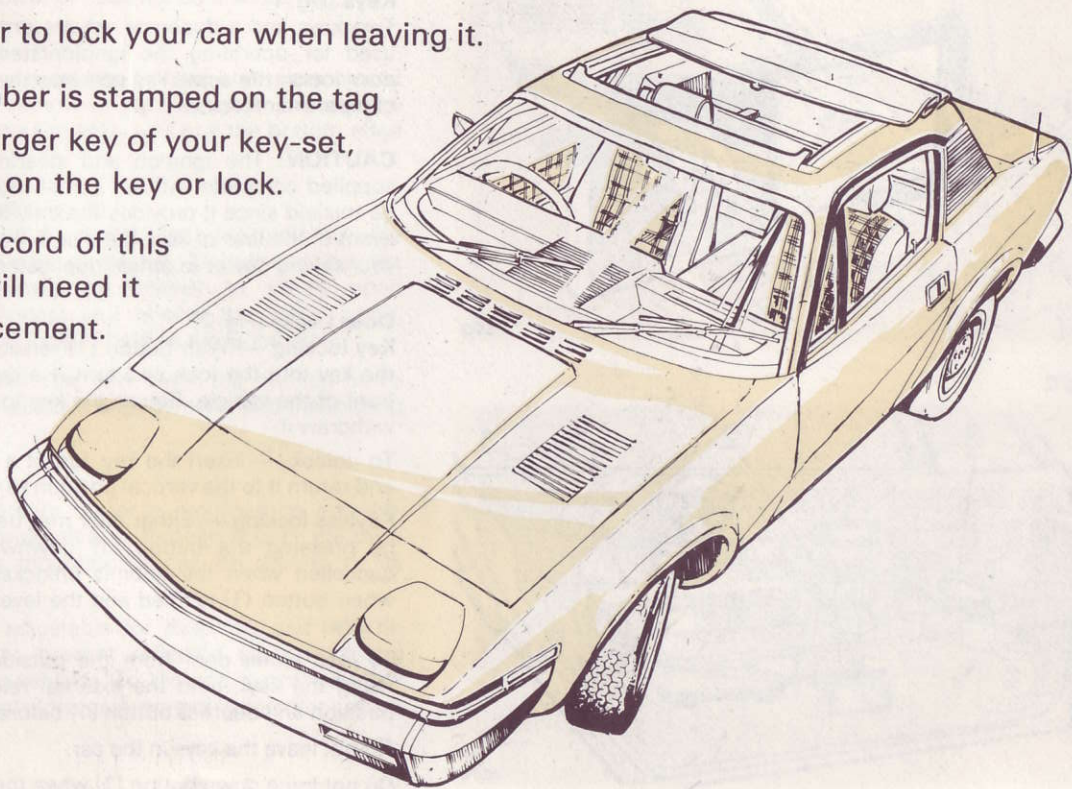

BODY FITTINGS

Fig. 1

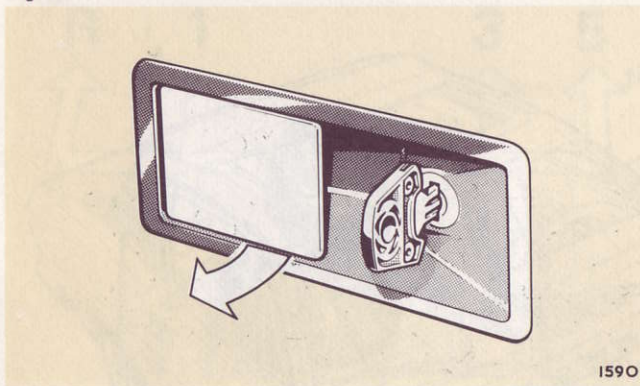
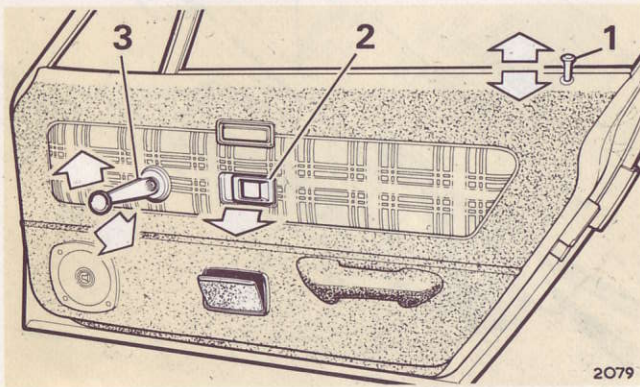

Fig. 2



BODY FITTINGS

Keys (Fig. 1)

Two keys and a duplicate set are provided. The large key is used for operating the ignition/steering-column lock and door locks; the small key operates the glovebox and luggage compartment locks.

CAUTION: The ignition and steering column lock key is supplied complete with an identification disc. This must not be mislaid since it provides the only record of the key. In the event of the loss of keys the disc will have to be submitted to your selling dealer to obtain duplicates.

Door Locks (Fig. 2)

Key locking — With button (1) raised, close the door, insert the key into the lock and turn it a quarter turn towards the front of the vehicle. Return the key to the vertical position to withdraw it.

To unlock — Insert the key, turn it a quarter turn rearwards and return it to the vertical position to withdraw it.

Keyless locking — Either door may be locked from the inside by pressing the button (1) downwards. This position is cancelled when the door is unlocked from the outside or when button (1) is lifted and the lever (2) is pulled from the inside.

To lock either door from the outside (as an alternative to using the key), hold the external release lever in the open position and depress button (1) before closing the door.

Do not leave the keys in the car.

Do not force down button (1) when the door is open.

Door Windows (Fig. 2)

Turn the handle (3) to lower or raise the door windows.

Ashtrays (Fig. 2)

Pull the top of the tray outwards for use and press closed when not required. To remove an ashtray, open, depress the spring clip to release the top edge and pull the bottom edge clear of the surround.

Bonnet Release Control (Fig. 3)

To open the bonnet, pull the control knob located below the fascia at the left-hand side of the car. This disengages the locking plate and allows the bonnet to spring open sufficiently to insert fingers and release the safety catch. When fully opened the bonnet is held by a support stay.

To close, disengage the stay and lower the bonnet, firmly pressing its catch into positive engagement with the locking plate.

Driving Mirror (Fig. 4)

The fully adjustable interior mirror is mounted on a break-away support for personal safety. If, through impact, the stem is dislodged from its mounting, it can be refitted to its original position.

The driving mirror is adjustable for direction, and may be 'dipped' temporarily to prevent reflected glare from the headlamps of following vehicles. To 'dip' the mirror move the protruding tab rearward; to regain normal adjustment move the tab forward.

Fig. 3

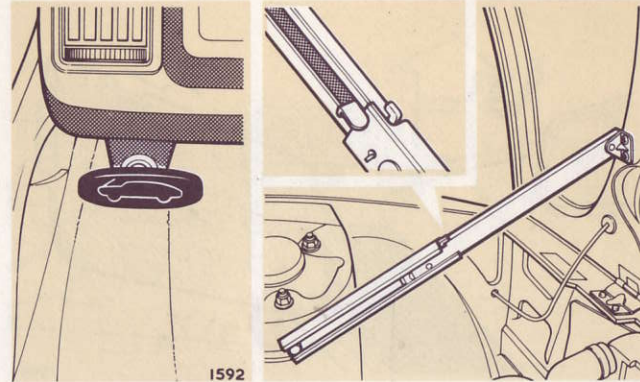
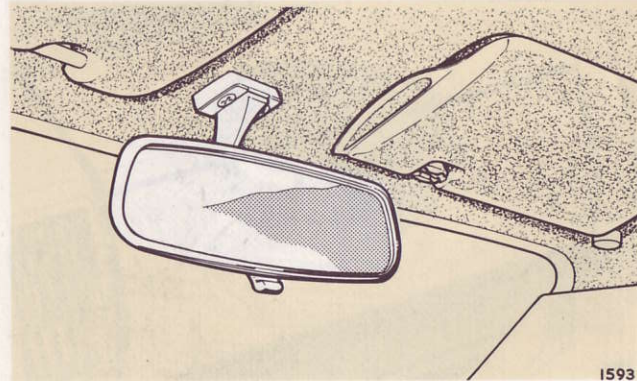
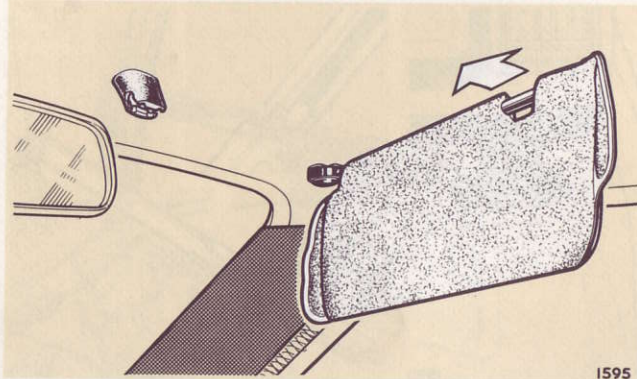

Fig. 4



BODY FITTINGS

Fig. 5



Sun Visors (Fig. 5)

Two adjustable sun visors (that on the passenger's side having a vanity mirror) are padded to reduce the risk of impact injury. Either visor can be swung downwards or can be unclipped from the driving mirror bracket and swung sideways to eliminate sun glare.

The driver's sun visor incorporates a ticket pocket.

Door Mirror

The driver's door mirror should be adjusted to provide an area of vision slightly overlapping that of the interior rear view mirror.

Fig. 6



Glovebox Locker (Fig. 6)

To open, turn the knob and lower the hinged lid. The lid is retained in the closed position by a spring catch.

Door Lamps (Fig. 7)

A three position lamp is fitted to each door.

With the lens flush (2) the lamp is 'OFF'. With the lens tilted up (3) the lamp is switched 'ON'. With the lens tilted down (1) the lamps operate when a door is opened.

Opening Roof (Optional) (Fig. 8)

To open the roof panel, pull the handle downwards, turn a half turn anti-clockwise and pull the panel rearwards. To close, reverse the procedure.

The roof panel may be locked in any position but the locking mechanism is not designed to hold against firm hand pressure.

Heated Back-light

The heated back-light window has the heating element on the inside surface of the glass and with reasonable care will last indefinitely. The following practices will damage the element and must be avoided:

1. Scratching off labels and advertising stickers.
2. Wiping the glass with the back of a ringed hand.
3. Stowing hard and metal objects so that they abrade the glass.
4. Cleaning with harsh abrasives.

Fig. 7

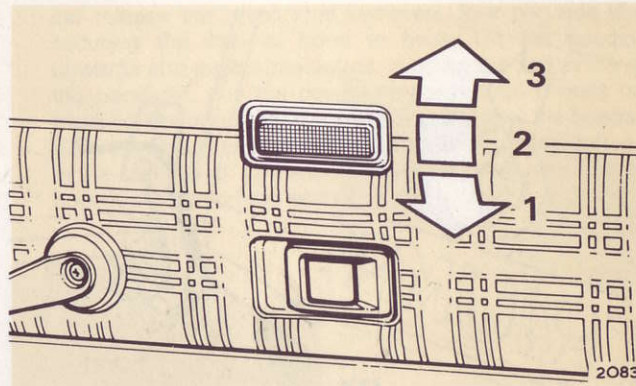
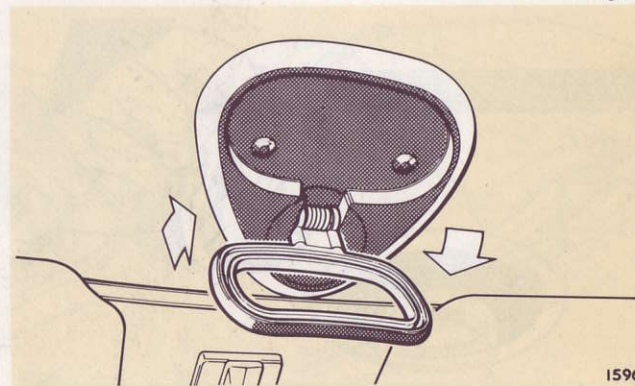

Fig. 8



BODY FITTINGS

Fig. 9

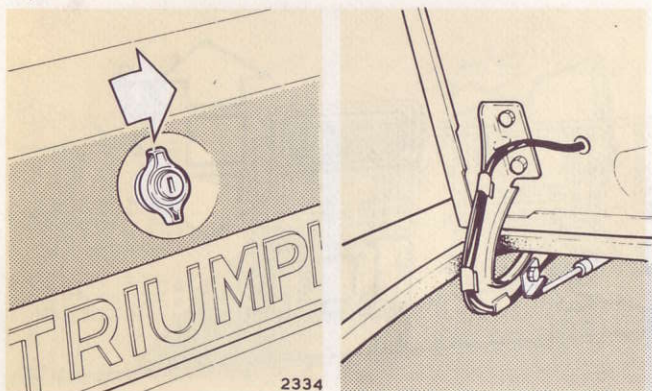
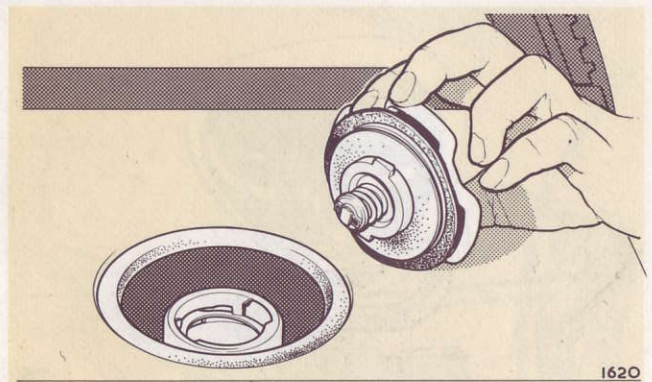

Fig. 10



Luggage Compartment (Fig. 9)

To open, turn the unlocked handle or the key in the lock, clockwise. Raise the lid to its limit and lower the lid onto its telescopic support.

To close, raise the lid to release the support catch, lower the lid and when nearly closed gently push the lid down to engage the lock catch.

To lock, insert the key, turn it anti-clockwise and withdraw the key.

The lid is self supporting on later vehicles. Follow the above instructions ignoring the reference to the telescopic support.

Interior Stowage Space

In addition to the glovebox, further stowage space is provided for small packages, maps, etc, in the centre console armrest in rear quarter panel pockets and on the rear shelf behind the seats. It is dangerous practice to place heavy or sharp objects on the rear shelf as these can become lethal projectiles in the event of an impact.

Fuel Filler Cap (Fig. 10)

To open, turn a quarter turn anti-clockwise and lift off.

Radio Facility

A manually operated radio aerial is fitted in the rear wing panel and is raised by lifting the protruding lip. Ensure that the aerial is lowered before entering an automatic car wash.

Loudspeaker units are fitted in the door panels.

Soft Top

The soft top is made from P.V.C. material, and is supported by a hinged frame. The assembly folds down into the rear of the car and is protected by a soft top cover.

Lowering Soft Top

Release the header rail from the windscreen frame by turning the two catch levers towards the inside of the car. Push the header rail upwards to disengage. From the outside of the

car release the press stud fasteners, four per side (Fig. 1) securing the side of hood to body. Lift the header rail upwards and push it rearwards. Holding the flap at the top of the backlight, pull the cover rearwards until it rests on the trunk lid, ensuring that it is not trapped under the header rail. With the hood flat, fold the rear quarter lights inwards on top of the cover, (Fig. 2) then fold the backlight forwards onto the hoodsticks behind the seats (Fig. 3).

Fig. 1

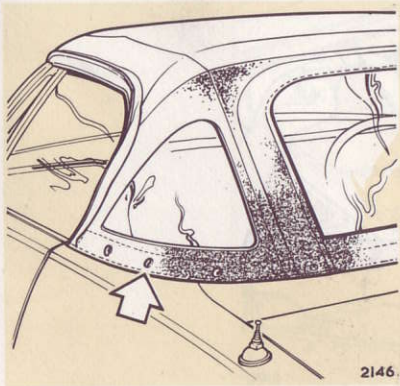

Fig. 2

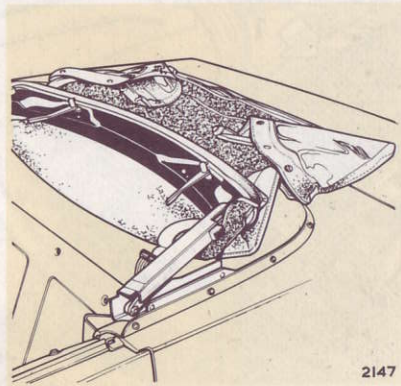
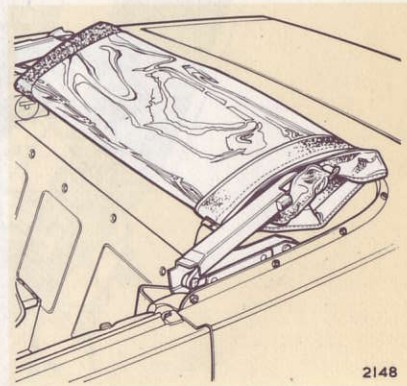

Fig. 3



BODY FITTINGS

Soft Top in the Down Position (Fig. 4)

Attach the hood cover to the fasteners working from the centre (1) outwards around the back rail. Locate the three fasteners (2) on the rear trim board, behind the seats and the two inside the door shut pillars (3).

Raising the Soft Top

Unfasten and remove the hood cover. Fold the fabric backwards over the trunk lid and fold out rear quarter lights.

Lifting the soft top header rail, raise the assembly to allow the fabric to lie evenly over the frame. Secure the header rail catches and turn the levers inwards. Fasten the four press stud fasteners on the side of the hood to the body.

Opening Rear Window (Fig. 5)

Pull the zip-fastener around the window and roll the window downwards.

Fig. 4

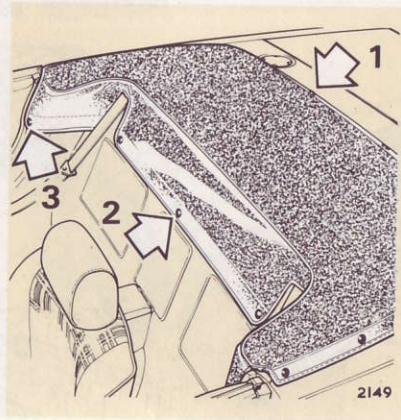
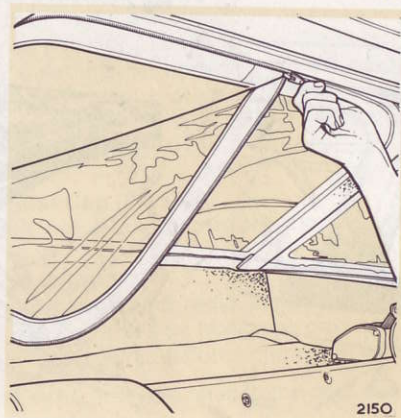

Fig. 5



Use your seat belts.

Statistics prove that the use
of safety belts saves lives.

Please use them.

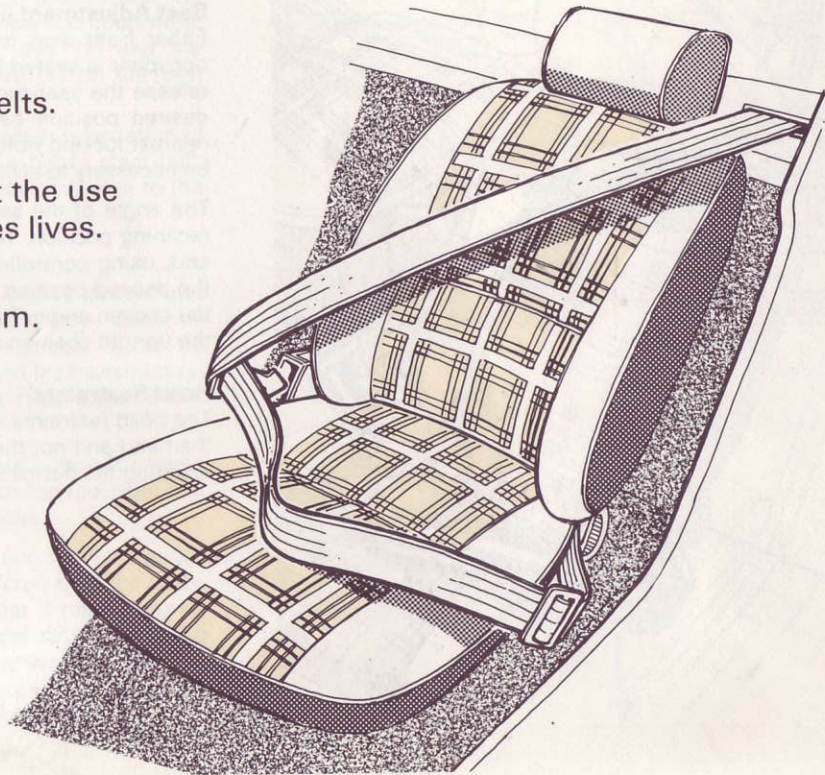

SEATS AND SAFETY HARNESS

Fig. 1

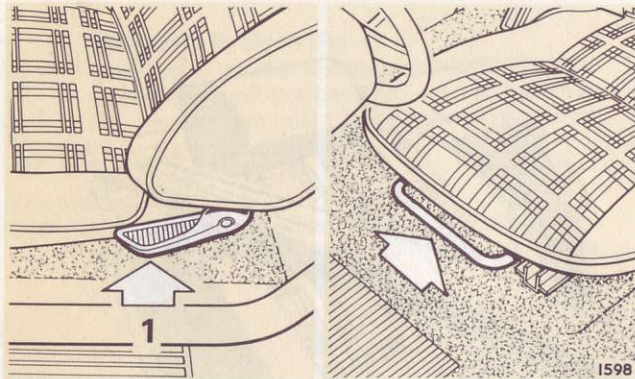

SEATS AND SAFETY HARNESS

Seat Adjustment (Fig. 1)

Either front seat can be adjusted for leg reach while the occupant is seated by lifting a bar against spring pressure to release the seat runner. The seat can then be moved to the desired position before allowing the bar to engage in its nearest locking notch. Some additional seat movement may be necessary to achieve this.

The angle of the seat back-rest can be altered to provide a reclining position. To achieve this, raise and hold the lever (1) and, using controlled body pressure, move the back-rest to the desired position. Release the lever to lock the back-rest at the chosen angle. The seat back, if unrestrained, will return to the upright position when the locking lever is raised.

Head Restraints

The head restraints should be adjusted to support the back of the head and not the neck. This can be achieved by lifting or lowering the device as required.

Fig. 2

Description of Inertia Reel Type Harness (Fig. 2)

One end of the harness (1) is attached to a self-retracting inertia reel mounted behind the passenger compartment. The harness passes through a 'running eye' (2) and the buckle (3) before passing to a fixed point (4) on the seat frame.

The harness is prevented from unreeling when retardation of the vehicle causes the displacement of a heavy steel ball. This tilts a pivoting plate which applies a positive lock to the reel mechanism.

Using the Harness (Fig. 3)

While seated, pull the buckle (3) until a loop is formed and pass the arm nearest the door through the loop. Continue pulling the harness over the hips until the buckle (3) can be inserted into the buckle unit (5) mounted on the transmission tunnel between the front seats. A positive 'click' ensures that the harness is safely locked.

To release the harness, depress the release button (6), when the harness tongue will automatically disengage from the buckle unit and retract towards the door pillar.

To obtain the maximum designed protection from the safety harness it is essential that it is properly fitted over the body. The lap strap (7) should be placed so that it rests securely over the bony part of the hips. The shoulder strap (1) should pass over the shoulder and diagonally downwards across the body. No adjustment is required as the automatic retraction of the reel retains the harness at the correct tension.

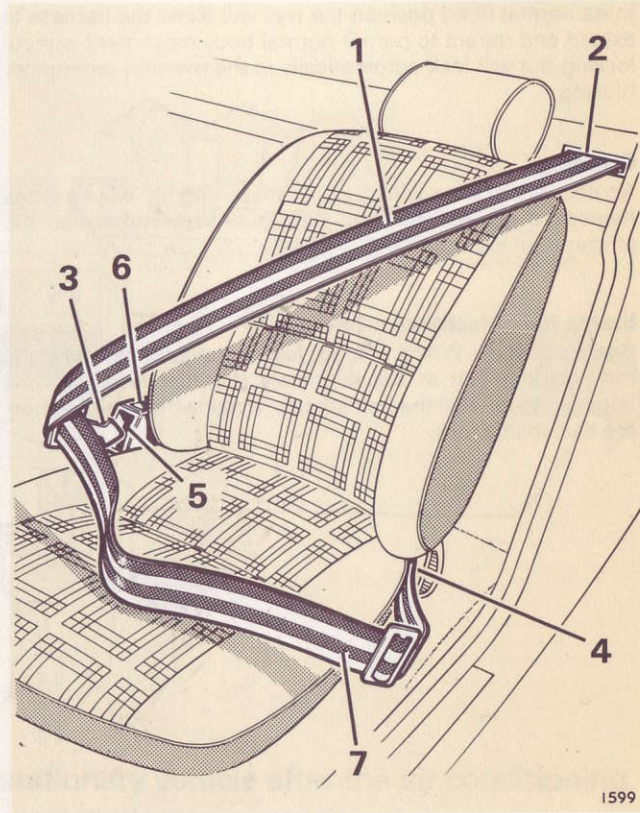

1599

SEATS AND SAFETY HARNESS

In its normal fitted position the reel will allow the harness to extend and retract to permit normal body movement without locking but will lock automatically in the event of emergency braking.

Cleaning

An occasional wipe with a warm soapy sponge will keep the harness clean. Do not use bleach or dyes otherwise the efficiency of the harness may be affected.

Inertia Reel Mechanism Check

Snatch Test — Whilst seated, fasten the seat belt and grip the shoulder belt at approximately shoulder level with the opposite hand. Pull the belt sharply in a downwards direction, the belt should lock.

The following road test must be carried out only under maximum safe road conditions, i.e. on a dry, straight, traffic free road.

With the safety harness fitted to the driver and passenger as previously described, drive the car at 8 km/h (5 m.p.h.); ensuring that it is safe to do so, brake sharply.

The safety harness should lock automatically, holding both driver and passenger securely in position.

It is important when braking that the reaction of both driver and passenger is normal, i.e. the body must not be thrown forward in anticipation, thus causing a 'snatching' action of the reel which will not operate the locking mechanism. The harness is locked by retardation of the car, not by body movement.

If the belt fails to lock on either test, consult your Dealer.

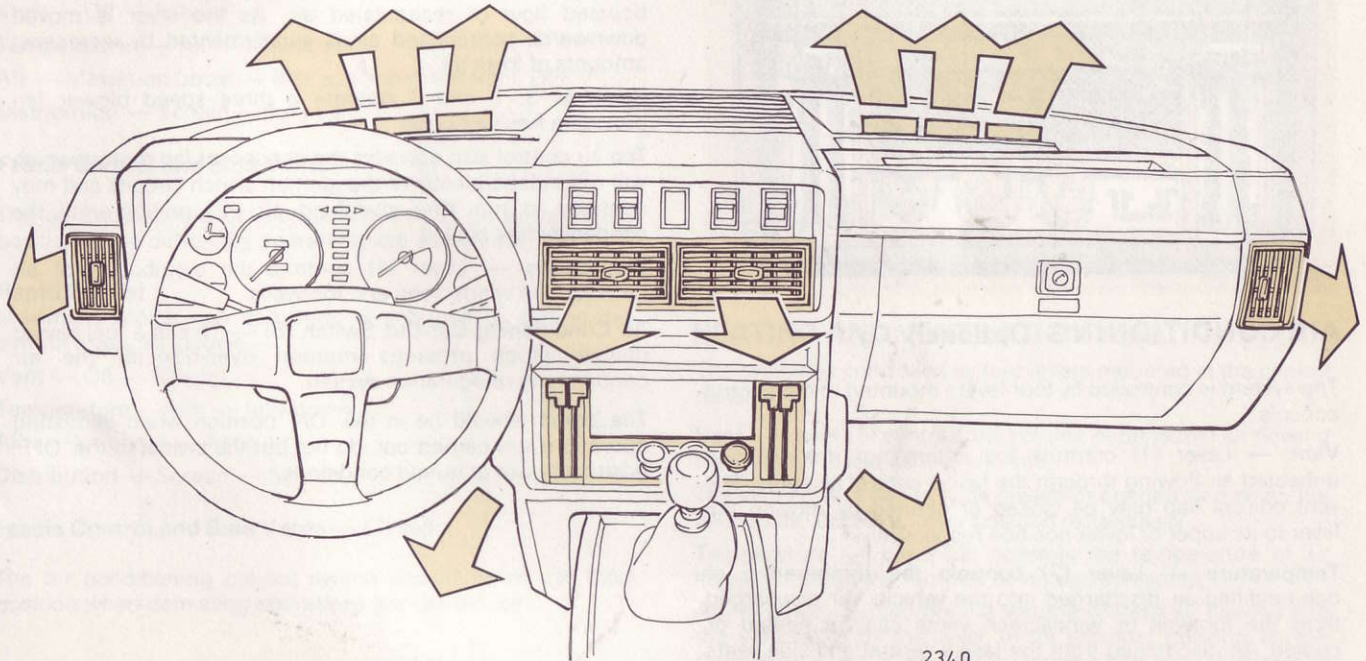

A pool of condensation may form underneath a stationary vehicle after the air conditioning has been used. This should not be mistaken for a leak from the cooling system.

HEATING, VENTILATION AND AIR CONDITIONING

Fig. 1

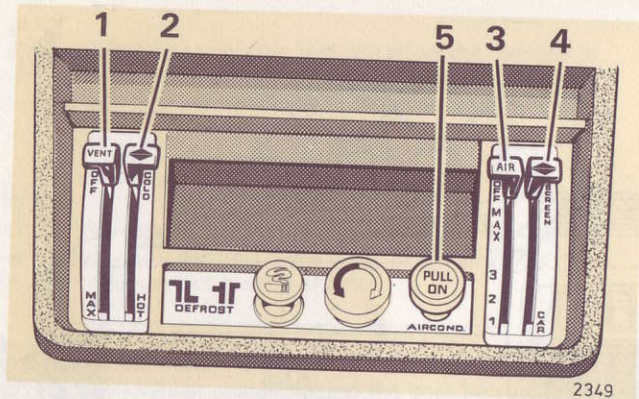

AIR CONDITIONING (Optional) (Fig. 1)

The system is controlled by four levers mounted in the central console.

Vent — Lever (1) controls the volume of dehumidified unheated air flowing through the fascia central air vents. The vent control flap may be closed or opened by moving the lever to its upper or lower position respectively.

Temperature — Lever (2) controls the temperature of dehumidified air discharged into the vehicle. Air discharged from the footwell or windscreen vents can be heated or cooled. Air discharged from the fascia central and side vents can be cooled, but not heated.

Air — Lever (3) controls the respective volumes of fresh or recirculated air flowing through the unit.

With the lever in its topmost position airflow through the unit is negligible.

Moving the lever to the first detent (Max.) provides maximum boosted flow of recirculated air. As the lever is moved downwards recirculated air is supplemented by increasing amounts of fresh air.

Positions 3, 2 and 1 operate a three speed blower fan providing fresh air only.

The air control also operates the condenser fan motors which will run independently of the ignition switch circuits and may continue to run after switching off the ignition until the condenser has cooled.

Distribution — Lever (4) controls the distribution of air between the windscreen and footwells.

Air Conditioning Cut-Out Switch (5) — This is a fuel saving device which provides manual over-ride of the air conditioning refrigeration system.

The switch should be in the 'ON' position when demisting operations are carried out, do not put the switch to the 'OFF' position in wet or humid conditions.

Fig. 2

Rapid 'Defrost'

Maximum windscreen defrosting is achieved by setting the control levers as follows:-

Vent — Off — fully up

Temperature — Hot — fully down

Air — Maximum boost — first position down from 'OFF'

Distribution — Screen — fully up

Fascia Control and Side Vents — Closed

The air conditioning cut-out switch should be in the 'OFF' position when defrosting operations are carried out.

Rapid Demist

Maximum windscreen demisting is achieved by setting the control levers as follows:-

Vent — Off — fully up

Temperature — Hot — fully down

Air — Position 3 — fresh air

Distribution — Screen — fully up

Fascia Control and Side Vents — Closed

The air conditioning cut-out switch should be in the 'ON' position when demisting operations are carried out.

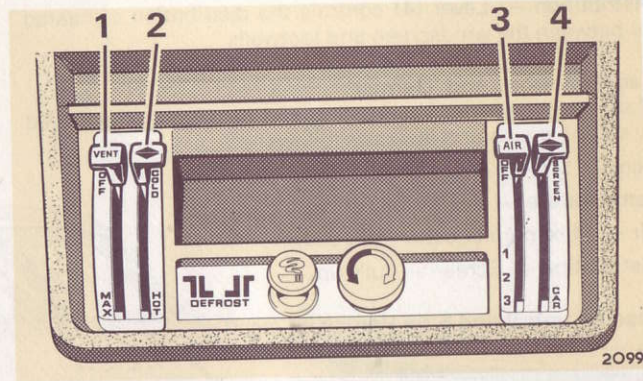

HEATING AND VENTILATION (Fig. 2)

The system is controlled by four levers mounted in the central console.

Vent — Lever (1) controls the volume of unheated air flowing through the fascia central air vents.

The vent control flap may be closed or opened by moving the lever to the upper or lower position respectively.

Temperature — Lever (2) controls the temperature of air flowing through the footwell or windscreen vents.

Air — Lever (3) controls the volume of fresh air flowing into the vehicle. With the lever in its topmost position airflow through the unit is negligible. Moving the lever downwards increases the air flow which can be boosted at low road speeds by further movement of the lever to positions 1, 2 and 3 which operates a blower fan at low or high speeds.

HEATING, VENTILATION AND AIR CONDITIONING

Distribution — Lever (4) controls the distribution of heated air between the windscreen and footwells.

Rapid 'Defrost' and 'Demist'

Maximum windscreen defrosting and demisting is achieved by setting the control levers as follows:-

Vent — Off — fully up

Temperature — Hot — fully down

Air — Maximum boost — fully down

Distribution — Screen — fully up

Fascia Control and Side Vents — Closed

Fig. 3

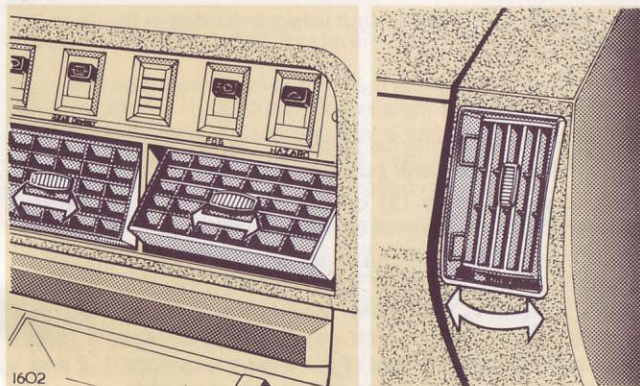

Fascia Side Vents (Fig. 3)

A swivelling air vent located at either end of the fascia is provided with a valve that can be opened or closed by turning the control knob below the vent.

This admits unheated air which can be directed as required by adjusting the vanes.

Fascia Central Air Vents (Fig. 3)

By suitable adjustment of the vent control lever, unheated air can be directed through the central air vents to the car interior. The flow may be directed as required by adjusting the vanes.

Air Extraction

Whilst the vehicle is in motion, stale air from the interior flows via slots located at the base of the rear window into the luggage compartment, from where it is extracted by a low pressure air stream through the grills in the roof quarter panels.

Footwell Ventilation (Non Air Conditioning)

Cold air may be admitted to the footwells by pushing open a flap valve located in the outboard side panel of each footwell.

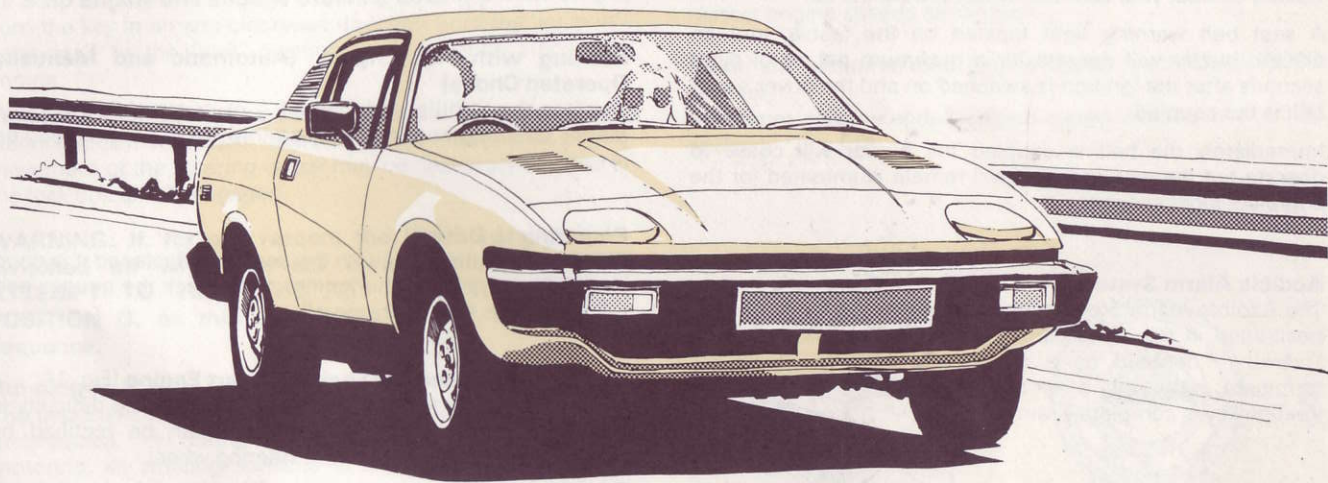

DO NOT attempt to turn the ignition key to the 'LOCK' position, whilst the vehicle is in motion.

RUNNING INSTRUCTIONS

RUNNING INSTRUCTIONS

Seat Belt Warning System

Your Triumph is fitted with a seat belt warning system which may save lives and encourage the use of seat belts.

The basis of the system is to warn you both audibly and visually to wear your seat belt whilst driving the car.

A seat belt warning light located on the fascia, and an electric buzzer will operate for a maximum period of eight seconds after the ignition is switched on and the driver's seat belt is not coupled.

Immediately the belt is coupled the buzzer will cease to operate but the warning light will remain illuminated for the complete eight seconds.

Audible Alarm System

The Audible Alarm System functions when the ignition key is positioned in the switch and the driver's door is open. The "warning" denoted by a continuous buzzing sound will terminate when the driver's door is closed or when the ignition key is completely removed.

Vehicle with Manually Operated Choke/Enrichment

Starting with engine cold — including sub zero ambients.

Pull choke control out fully to start engine. Operate starter and maintain continuous engagement until the engine starts. As soon as the engine starts push the choke control in until the engine speed is approximately 1100 - 1300 rpm. The

choke control should be pushed in fully as soon as the engine will maintain normal idle speed without its use.

Vehicle with Automatic Choke/Enrichment

Starting with cold engine — including sub zero ambients.

Operate starter and maintain continuous engagement until engine starts and runs.

Starting with Hot Engine. (Automatic and Manually Operated Choke)

Depress the throttle pedal about $\frac{1}{3}$ of its travel and engage starter until engine runs. Release throttle as soon as engine is running.

Preparing to Drive

When seated in the car with the seat belts fastened it is good practice to switch on the ignition and check the gauges and warning lights before driving off.

To Disengage Steering Lock and Start Engine (Fig. 1)

Insert the key and turn in clockwise direction. If difficulty is experienced in turning the key, this can be rectified by simultaneous movement of the steering wheel.

Turn the key clockwise to position 2 (Ignition) the ignition will be switched on.

To start the engine, the key should be turned a little more against spring pressure to position 3 ('start'), as soon as the engine fires release the key which will return automatically under spring pressure to the ignition position 2.

Do not operate the starter for longer than five to six seconds and wait until the engine has stopped before re-using the starter. If after a few attempts the engine fails to start, switch off the ignition and investigate the cause. Continued use of the starter will not only discharge the battery but may also damage the starter.

To Stop Engine and Engage Steering Lock

Turn the key in an anti-clockwise direction from the 'ignition' position 2 to the 'lock' position 0. This action stops the engine.

Removal of the key in this position automatically actuates the steering lock mechanism. (See Audible Alarm System). Slight movement of the steering wheel may be necessary to ensure the lock bolt is fully engaged.

WARNING: If, for any reason, the (ignition) engine is switched off while the car is in motion DO NOT ATTEMPT TO TURN THE KEY INTO THE "LOCK" POSITION 0, as this constitutes part of the locking sequence.

Running-in

The importance of correct running-in cannot be too strongly emphasized, for during the first few thousand miles of motoring, all working surfaces of the vehicle are 'bedding down'.

Avoid placing heavy loads upon the engine, such as using full throttle at low speeds or when the engine is cold. Running-in should be progressive and no harm will result from the engine being allowed to 'rev' fairly fast for short periods provided that it is thoroughly warm and not pulling hard.

Always select a lower gear if necessary to relieve the engine of load. Full power should not be used until at least 1,600 km (1,000 miles) have been covered, and even then it should be used only for short periods at a time. These periods can be extended as the engine becomes more responsive.

Maximum Engine Speeds

After running-in has been completed, drivers are advised to restrict engine speeds as follows:

Maximum recommended engine speed (continuous) 6000 rev/min.

Maximum recommended engine speed (intermittent) 6500 rev/min.

Fig. 1

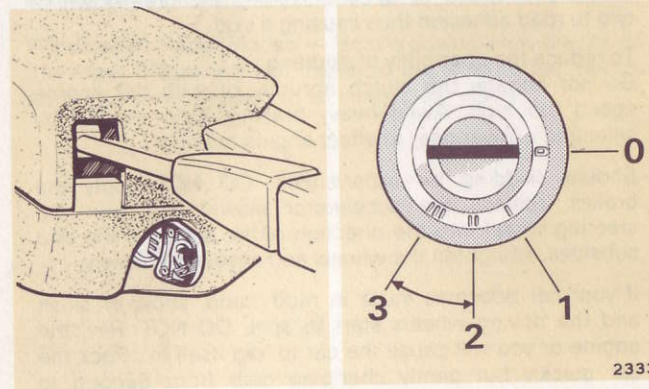

2333

RUNNING INSTRUCTIONS

General Driving Hints

By adopting the following driving habits greater economy can be obtained.

- Keep the engine properly maintained, by following the recommended maintenance schedules.
- Follow at a safe distance behind other vehicles. Sudden stopping causes excessive brake wear and extra fuel is required to accelerate back to driving speed.
- Do not 'Pump' the accelerator pedal. Move easily to a safe driving speed and try to maintain it.
- Speeds above 50 m.p.h. (80 km/h) considerably increase fuel consumption.
- When driving in adverse conditions, adopt a driving technique which avoids sudden movements. Abrupt changes of speed or direction allows the breakdown of tyre to road adhesion thus causing a skid.
- To reduce the possibility of skidding:—
Do not engage the clutch abruptly or with the engine speed too high. Avoid heavy braking, slow the car by selecting a lower gear to effect engine braking.
- Should skidding be experienced, DO NOT apply the brakes, release the accelerator slowly and turn the steering wheel into the direction of the slide. As the skid subsides, straighten the wheels and accelerate slowly.
- If your car becomes stuck in mud, sand, snow or slush and the driving wheels start to spin, DO NOT 'Rev' the engine or you will cause the car to 'dig itself in'. Rock the car quickly but gently changing gear from Second to Reverse to Second until the car eases away from its bogged down area.
- If rocking does not free the car, a footwell or luggage compartment mat placed under the driving wheels may give the required grip. Do not forget to retrieve the carpets when you reach safe ground.
- Adverse driving conditions can be categorised as follows:
Poor Visibility:- Fog, Mist, Heavy rain or snow.
Slippery Surfaces caused by:- Ice, Rain, Snow, Mud, Leaves, or Loose Road Surfaces (Road Under Repair).

Towing

For recovery the car should be towed with the key in the ignition/steering lock at position 1. For tow-starting the key should be at position 2.

See special instructions for Automatic Transmission (where fitted).

Two towing brackets are fitted beneath the front bumper. It is recommended that when towing, ropes are attached to either, but not both brackets.

Roof Rack

Bulky rather than heavy loads **no greater than 50 kg (110 lb.) may be carried on a roof rack**. Any load on the roof may affect the handling of the car, especially in a cross wind or when cornering.

Use of the Clutch

It is bad practice to drive with the foot resting on the clutch pedal as this will cause 'Clutch Slip' and excessive wear.

When the vehicle is stationary with the engine running, the gear lever should be in neutral with the clutch pedal released.

Hill Driving

To minimise excessive wear on the clutch when starting on a hill, prudent use of the handbrake, accelerator and clutch is very important.

Winter Driving Hints

Freeing a Frozen Door Lock — Apply De-Icer or Glycerine through the keyhole to prevent the door lock freezing. Should the lock become frozen, heat the key before use.

Parking — In freezing conditions, where possible, park on a level surface, select First or Reverse gear, and turn the front wheels into the kerb. Care must be taken to straighten the wheels before attempting to drive away.

Windscreen Wiper Blades — Before driving away ensure that the wiper blades are not frozen to the windscreen. Remove ice from the windscreen to facilitate clear vision.

TOWING A CARAVAN OR TRAILER

TOWING A CARAVAN OR TRAILER

The following information is of a general nature and should be used in the light of regulations prevailing in the territories concerned for the type of Caravan or Trailer being towed. Laws concerning towing vary in different countries and it is advisable to ensure that the car and the vehicle to be towed comply with existing regulations. The main Motoring Organisations can provide such information.

This information applies to travelling on made-up metalled roads and not on dirt roads or across country.

Safety, stability and comfort are the essentials that must be satisfied when towing is being considered.

The kerbside weight of the car can be found in the General Specification section of the Maintenance Handbook.

The unladen weight of the Caravan or Trailer will be included in the manufacturers catalogue or handbook together with the gross laden weight, that is, the unladen weight plus the weight of personal effects and equipment.

Owners new to towing should bear in mind the effect on the cars performance when deciding the weight of Caravan or Trailer to be towed. Provided the maximum weight is not exceeded the influence on handling hillclimbing, acceleration and fuel consumption, whilst being apparent, should be acceptable. As towing imposes additional strain upon the

engine, transmission, suspension, brakes and tyres, **owners who constantly tow loads should have their car serviced more frequently.**

Tow Bar

It is important that only an approved tow bar is fitted. A specially designed tow bar for your car is available from your Dealer who will fit the tow bar, supply a tow ball and make the necessary electrical connections.

Alternatively a tow bar kit, which includes instruction, is available for owners who wish to do their own installation.

Nose Weight (The weight applied to the towbar when stationary)

Whilst the noseweight on most trailers, such as horse boxes remains fairly constant it can vary considerably with Caravans according to the weight and distribution of the load. All Caravan and Trailer manufacturers recommend a maximum nose weight and in the interest of stability it is unwise to exceed this figure. Generally the recommended weight is between 45 to 55 kg (99 to 121 lbs) which allows a sufficient margin for individual preference and trimming to give the best towing performance.

Most Caravan accessory stores sell noseweight gauges which are simple to use and enable frequent checks to be made. Another method is to place a stout piece of timber between the coupling and ordinary bathroom scales with the jockey wheel clear of the ground. Ensure that the parking brake is applied for safety.

Tow Ball Hitch Height

An important factor in towing stability is the height from the ground to the centre of the tow ball. The approved tow bar kit will ensure that with both vehicles on level ground and carrying their full permitted loads, the hitch height will, subject to the Caravan or Trailer nose weight being correct, provide a level or preferably slightly nose-down attitude.

Whilst most Caravan and Trailer manufacturers conform to this standard, some recommend a lower hitch height. In this case it will be necessary to fit a 'drop plate' which is a flat plate that bolts on the tow bar in place of the tow ball and the ball may then be fitted to give the correct height. Drop plates are available with holes at various distances apart to suit individual requirements.

Electrical Connections

A full range of lighting and direction indicator accessories that comply with statutory regulations are available from Dealers. Full instructions are included in the Kit for owners carrying out their own installation. However, it is essential that the regulations for lighting requirements are checked for the type of Caravan or Trailer and the territories in which towing is contemplated.

Loading the Car

The maximum loading of the car is 420 kg (925 lb) which includes people and luggage. When towing with this load, luggage to the equivalent nose weight of the Caravan or Trailer must be removed from the car.

Towing Mirrors

It is a legal requirement when towing in some countries to fit an extra mirror to the off-side of the car. In the interest of safety, however, it is suggested that one is also fitted to the near-side.

Taking to the Road

Assuming that all the maintenance operations have been carried out on the car and vehicle to be towed, make these checks before starting a journey.

1. Ensure that the ball coupling spring safety device is engaged.
2. The seven pin socket is connected to the car.
3. The reversing mechanism is disengaged.
4. The jockey wheel is raised and properly secured.
5. The Caravan corner steadies are fully raised.
6. The Caravan or Trailer doors, windows and ventilation vents are closed.
7. The gas bottles are secure.
8. That all lights and indicators are working.
9. That driving mirrors are adjusted.
10. That the Caravan or Trailer parking brake is released.

TOWING A CARAVAN OR TRAILER

The following advice may be helpful to owners new to towing.

1. Since the Caravan or Trailer may be wider than the car, care should be taken when negotiating bends at speed particularly when there is a kerb.
2. Because a Caravan or Trailer takes almost the same line as the car there is no need to over steer on bends.
3. Remember the extra length when overtaking. On freeways in particular, it is very easy to forget that one is towing.
4. Take extra care when passing cyclists.
5. Make constant use of mirrors.
6. Always brake gently and in good time.

TOWING A CARAVAN OR TRAILER

Recommended Maximum Trailer and Gross Train Weights

Braked Trailers/Caravans

Towing vehicle load conditions — 2 up

Restart gradient at sea level — 1 in 8 (12½%)

Trailer weight — 1016 kgs (2240 lbs)

With additional payload, such as luggage, the equivalent extra weight should be deducted from the maximum recommended trailer weight.

With extra care, braked trailers in excess of the above weight may be towed. The Gross Train Weight should not exceed:

Manual Transmission — 2680 kgs (5908 lbs)

Automatic Transmission — 2620 kgs (5776 lbs)

Restart gradient at sea level 1 in 10 (10%)

Gross Train Weight is the Gross Vehicle Weight plus maximum trailer weight.

When towing a trailer the towing vehicle maximum rear axle load must not be exceeded.

The recommended static vertical nose load (A) at trailer hitch is 50 ± 5 kgs (110 ± 11 lbs)

Fig. 1

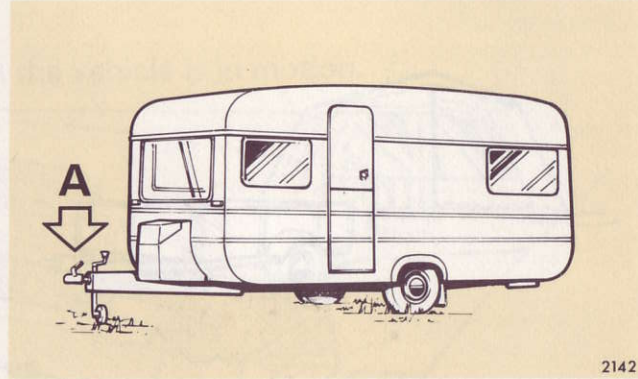

2142

Fig. 2

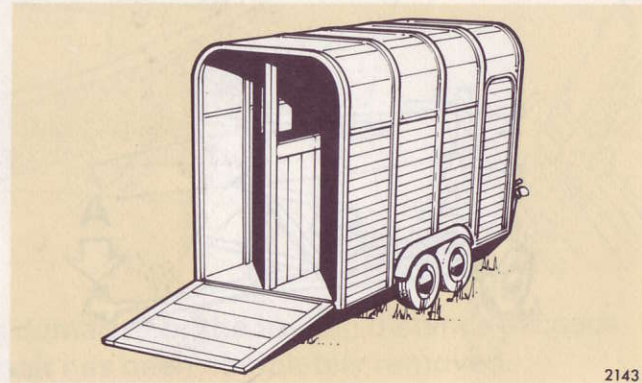

2143

TOWING A CARAVAN OR TRAILER

Fig. 3

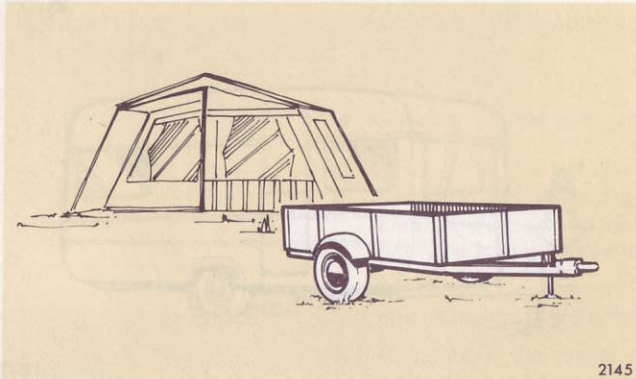
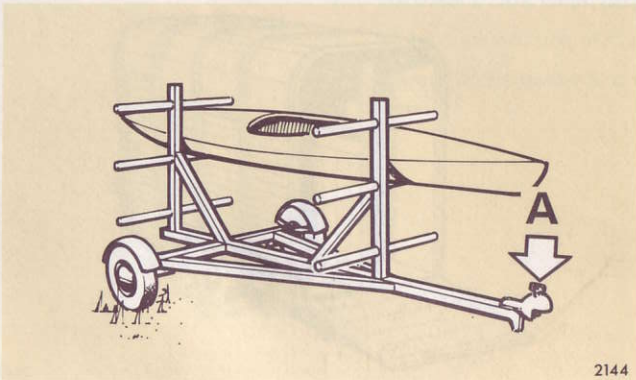

Fig. 4



Recommended Maximum Trailer and Gross Train Weights

Unbraked Trailers

Towing vehicle load conditions:

Trailer Weight — 1 Up — 495 kgs (1091 lbs)
— G.V.W. — 315 kgs (694 lbs)

Gross Train Weight:

Manual — 1655 kgs (3649 lbs)
Automatic — 1625 kgs (3583 lbs)

Gross Train Weight is the Gross Vehicle Weight plus maximum trailer weight.

When towing a trailer the towing vehicle maximum rear axle load must not be exceeded.

The recommended static vertical nose load (A) at trailer hitch is 50 ± 5 kgs (110 ± 11 lbs)

Gross Vehicle Weight — Manual — 1340 kgs (2954 lbs)
— Automatic — 1310 kgs (2888 lbs)

Max. Rear Axle Load — Manual — 665 kgs (1466 lbs)
— Automatic — 630 kgs (1389 lbs)

DO NOT select 'PARK' whilst the vehicle is in motion.

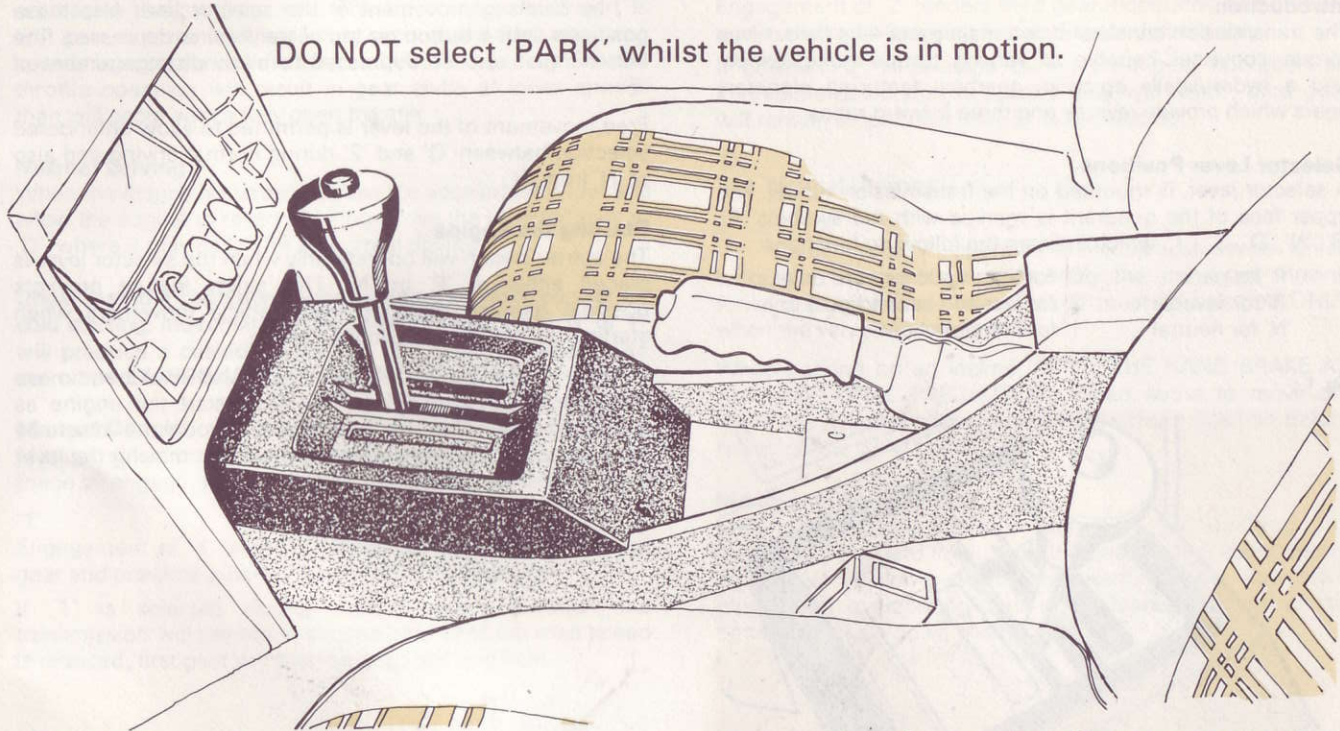

DO NOT tow the vehicle if the transmission is damaged or the towing distance exceeds 48 Km (30 miles), unless the propellor shaft has been completely removed.

AUTOMATIC TRANSMISSION

AUTOMATIC TRANSMISSION

Introduction

The transmission consists of two main parts — a fluid driven torque converter capable of varying torque-multiplication, and a hydraulically epicyclic gearbox, featuring planetary gears which provide reverse and three forward ratios.

Selector Lever Positions

A selector lever, is mounted on the transmission tunnel. The upper face of the quadrant is marked with the symbols 'P', 'R', 'N', 'D', '2', '1', which indicate the following functions:

- | | |
|------------------|-------------------------------------|
| 'P' for park. | 'D' for automatic forward drive. |
| 'R' for reverse. | '2' for first and second gear only. |
| 'N' for neutral. | '1' for first gear hold. |

Fig. 1

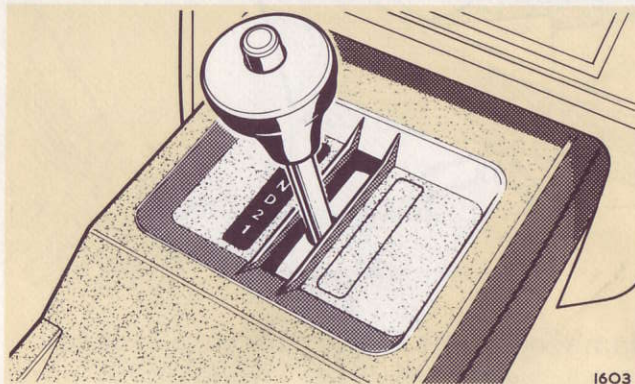

A safety lock prevents inadvertent selection of 'R', 'P', 'N' or '1', by baulking movement of the selector lever into these positions until a button on top of the lever is depressed. The button must also be depressed to allow disengagement of 'P'.

Free movement of the lever is permitted to allow unhindered selection between 'D' and '2' during normal driving and also of 'N' from 'R'.

Starting the Engine

The starter switch will operate only when the selector lever is placed either in 'P' or 'N'. This safety feature prevents possible damage resulting from vehicle movement when starting the engine in a confined space.

For normal starting, first APPLY THE HANDBRAKE and move the selector lever to 'P' or 'N'. Then start the engine as described under 'Running Instructions'. Should the vehicle be on a steep incline, start the engine without moving the lever from 'P' position (See 'P').

Release the hand brake and use the accelerator pedal to accelerate the car from rest. The transmission will start in first gear, automatically selecting second and third at varying speeds in accordance with load and throttle opening. Smaller throttle openings will result in gear shifts at lower speeds than will occur with a fully open throttle.

Normal Driving

When the engine is started, release the accelerator pedal and allow the engine to revert to idling. Move the selector lever to 'D', where it may be left for all normal driving.

Under fast idle conditions, when using the choke control for cold starting, movement of the selection lever from 'N' or 'P' will produce a cushioned thump; this is not detrimental to car or transmission.

Manual Control

Manual selection of first, second and third gears can be made by engaging '1', '2' and 'D' in sequence.

'1'

Engagement of '1' from rest holds the transmission in first gear and prevents automatic up-shift to second gear.

If '1' is selected during second gear operation the transmission will remain in second gear until the road speed is reduced; first gear will then be engaged and held.

'2'

Engagement of '2' renders third gear inoperative and permits automatic shifts between first and second gears only.

If position '2' is selected during third gear operation an immediate down-shift to second gear will result; third gear will remain inoperative until 'D' is re-selected.

'D'

See 'Normal Driving'.

'P'

Selection of 'P' operates a mechanical device which locks the transmission, preventing the car from moving forward or backward. This position must be selected ONLY when the vehicle is at rest.

When parking on an incline, APPLY THE HAND BRAKE AS AN ADDITIONAL PRECAUTION. When about to move off, move the selector to the appropriate driving position before releasing the hand brake.

Maximum Acceleration

Maximum acceleration is achieved by pushing the accelerator pedal to the full throttle position, i.e. about seven-eighths of available pedal movement. Further downward movement, overcoming built-in resistance, will bring the pedal to the kick-down position.

AUTOMATIC TRANSMISSION

Automatic Down-shifts

Down-shifts will occur in relation to throttle position and load, or when the accelerator is depressed to the kick-down position. To protect the engine, down-change speeds are pre-set.

Halt/Manoeuvring/Creep

To halt the vehicle in traffic, release the accelerator pedal and apply the footbrake. It will be noted that there is a slight 'creep' when the engine is idling and the selector is at '1', '2' or 'D'. This feature can be used to advantage in traffic, or to hill-hold on a slight incline, when the vehicle will be prevented from rolling backwards. Use can be made of the tendency to creep when manoeuvring the car in a confined space, or when moving away on icy roads.

To avoid overheating when '1', '2', 'D' or 'R' is selected and the vehicle is stationary, do not run the engine above idling speed except when using the choke (Canadian Specification only). Select 'P' or 'N' for prolonged periods of idling.

Emergency Braking Procedure

FIRST GEAR MUST BE ENGAGED AND RETAINED before descending long steep gradients, such as those encountered in mountainous regions. To achieve this, adopt either of the following procedures:

1. Stop the vehicle, move and retain the selector in position 1.
2. Move and retain the selector in position '1' and reduce the road speed below the 2 — 1 Shift speed given in the 'General Specification'.

Towing

When ascending long gradients steeper than 1 in 15 whilst towing a caravan, etc., engage position '1'.

Emergency Starting

An emergency start cannot be made by towing or pushing

Vehicle Recovery

For local recovery, the vehicle can be towed a maximum distance of **48 km (30 miles)** at a speed NOT EXCEEDING **48 km/h (30 m.p.h.)** provided that the transmission is undamaged, the selector lever is at 'N' and ignition key is turned to position '1'. An extra 3.6 U.S. pts. (3 pints) of the recommended fluid must be added to the gearbox through the filler tube.

After towing the oil level should be corrected before the vehicle is driven under its own power.

If the transmission unit is damaged, or if the towing distance will exceed **48 km (30 miles)** the propeller shaft must first be completely removed. Alternatively, the car can be towed while the rear wheels are lifted.

When changing a road wheel, remember:-

1. Use firm, level ground. 2. Apply the handbrake. 3. Chock one of the other wheels.

Steel braced tyres must only be repaired by a recognised tyre specialist.

Temporary repairs are NOT allowed.

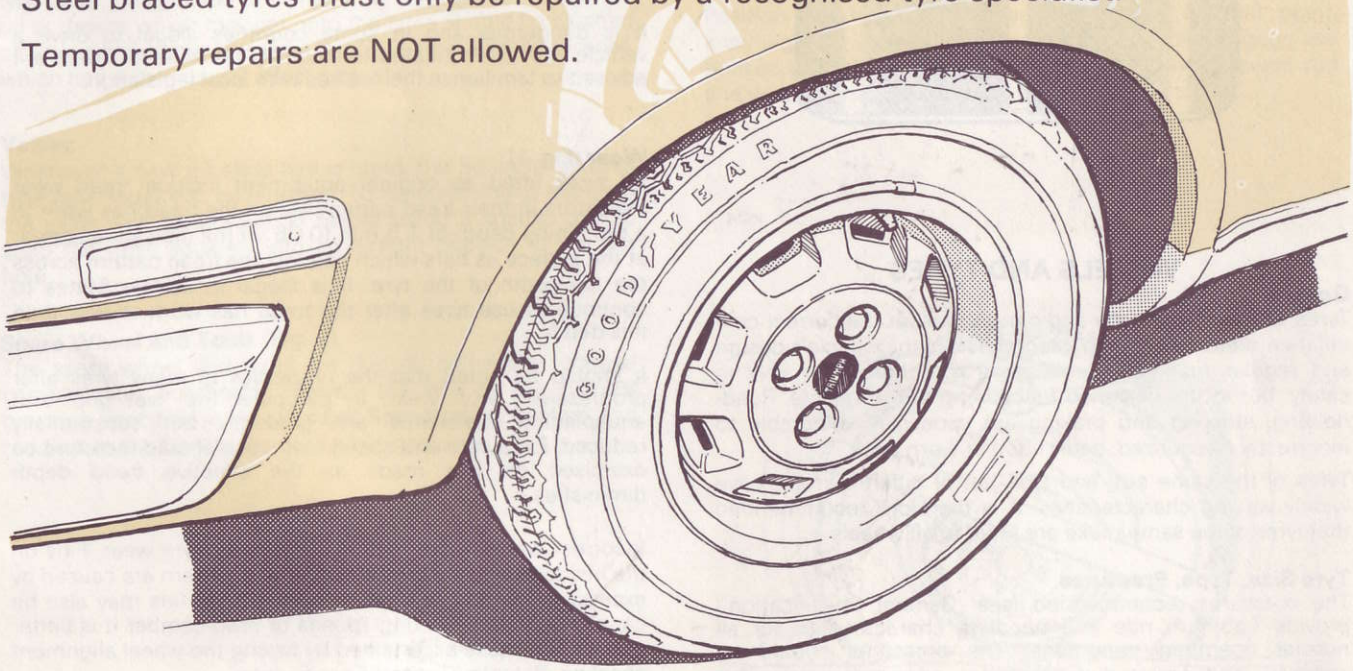

WHEELS AND TYRES

Fig. 1

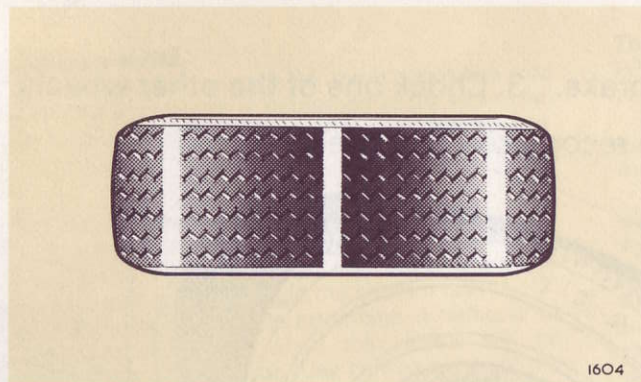

WHEELS AND TYRES

General

Tyres of the correct type and dimensions, at the correct cold inflation pressures, are an integral part of the vehicle's design and regular maintenance of tyres contributes not only to safety, but to the designed functioning of the vehicle. Road-holding, steering and braking are especially vulnerable to incorrectly pressurized, badly fitted or worn tyres.

Tyres of the same size and type but of different make have widely varying characteristics. It is therefore recommended that tyres of the same make are fitted to all wheels.

Tyre Size, Type, Pressures

The pressures recommended (see 'General Specification') provide optimum ride and handling characteristics for all normal operating conditions. The pressures should be checked, and adjusted if necessary, once per week. This

should be done with the tyres cold. Tyre temperatures and pressures increase when running. Bleeding a warm tyre to the recommended pressure will result in under-inflation which may be dangerous. A slight natural pressure loss occurs with time. If this exceeds 0.14 kg/cm^2 (2 lb/in^2) per week, the cause should be investigated and rectified.

It is dangerous and in some countries illegal to drive a vehicle with tyres inflated to incorrect pressures. Drivers are advised to familiarise themselves with local legislation.

Wear (Fig. 1)

All tyres fitted as original equipment include tread wear indicators in their tread pattern. When the tread has worn to a remaining depth of 1.5 mm (0.06 in) the indicators appear at the surface as bars which connect the tread pattern across the full width of the tyre. It is illegal in certain States to continue to use tyres after the tread has worn to less than this depth.

It should be noted that the properties of many tyres alter progressively with wear. In particular the 'wet grip' and aquaplaning resistance are gradually but substantially reduced. Extra care and speed restriction should therefore be exercised on wet roads as the effective tread depth diminishes.

Incorrect wheel alignment will accelerate tyre wear. Fins on the inside or outside edges of the tread pattern are caused by excessive toe-in or toe-out respectively. As fins may also be caused by high cornering speeds or road camber it is better to have the cause ascertained by having the wheel alignment checked. Refer to 'General Specification'.

Damage

Excessive local distortion can cause the casing of a tyre to fracture and may lead to premature tyre failure. Tyres should be examined especially for cracked walls, exposed cords, etc. Flints and other sharp objects should be removed from the tyre tread; if neglected they may work through the cover. Any oil or grease which may get onto the tyres should be cleaned off using a suitable cleaner. Do not use paraffin (kerosene), which has a detrimental effect on rubber.

Valves

Whenever a new tubeless tyre is fitted, the Schrader snap-in type valve must also be renewed. To facilitate fitting, lubricate the valve with soap solution before using a special tool to snap the valve squarely into an airtight position in the rim hole.

Spare Wheel and Tools (Fig. 2)

The spare wheel and tools are housed below the luggage compartment floorboards. Inflate the tyre to the highest pressure specified in the 'General Specification' section and readjust to the correct pressure when required.

Lifting Jack (Fig. 3)

Two jacking points are provided at each side of the car under the sills, one forward of the rear wheel and the other rearward of the front wheel. The jacking points are conical pins which accommodate the top plate of the lifting jack.

Position the head of the jack under the relevant point, ensuring that it locates correctly over the pin. Engage the hooked end of the handle with the eye of the screwed rod and wind the handle to take the weight of the car.

Fig. 2

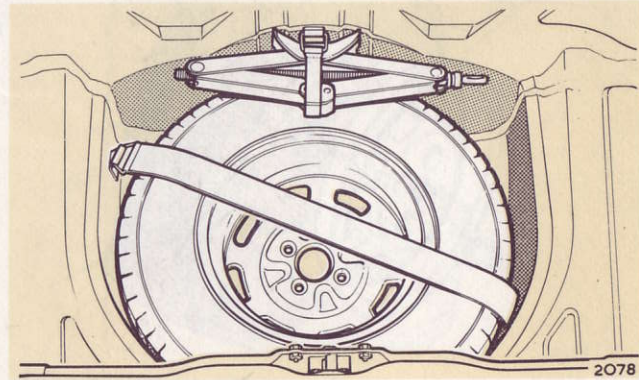

WHEELS AND TYRES

Fig. 3

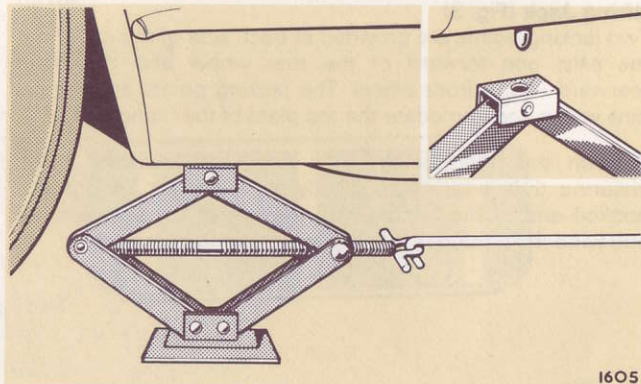
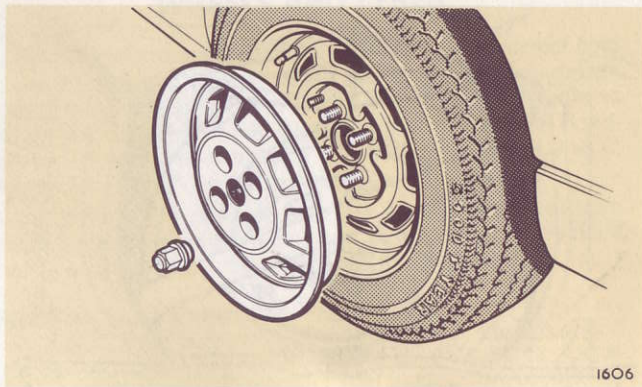

Fig. 4



WARNING: It is unsafe to work under the car using only the jack to support it. Always use stands or other suitable supports under the rear axle or front chassis members to provide adequate support and safety.

Neglect of the jack may lead to difficulty in a roadside emergency. Examine the jack occasionally, clean and grease the thread to prevent the formation of rust.

Road Wheel and Securing Nuts (Fig. 4)

Should it be necessary to lift the vehicle when on an inclined road surface, exercise the greatest care. Firmly apply the handbrake and chock one of the wheels not being lifted.

Remove the spare wheel from the luggage compartment and make sure that its pressure is correct.

Place the jack in position, slacken the wheel nuts and lift the wheel clear of the ground.

Completely remove the wheel nuts, remove the hub trim, exchange the road wheels and replace the hub trim and wheel nuts.

Lower the jack and securely tighten the wheel nuts.

CAUTION: The optional cast alloy road wheels combine lightness with great structural strength but are susceptible to localised damage that could result from the careless use of hammers, levers or spanners etc. Therefore to avoid damage take great care to ensure that the wheel nuts are fully seated before finally tightening alternate nuts.

Protect the engine by using an approved antifreeze or inhibitor in the cooling system.

Always exercise great care when removing the pressure cap from a hot engine.

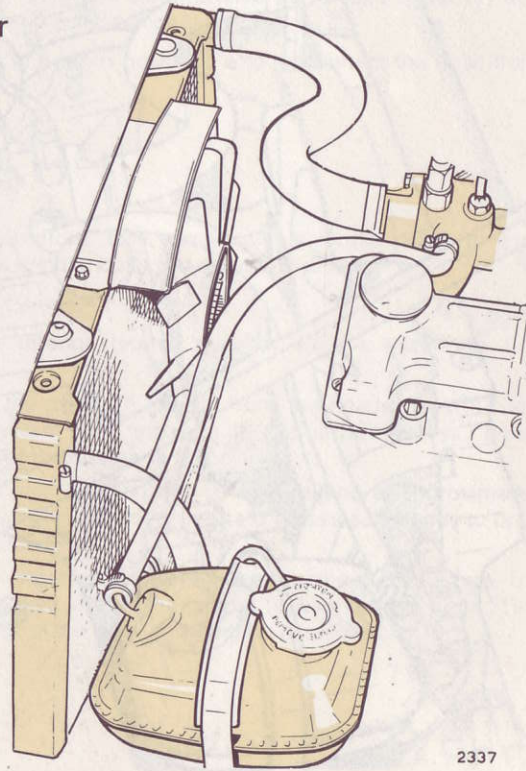

2337

COOLING SYSTEM

Fig. 1

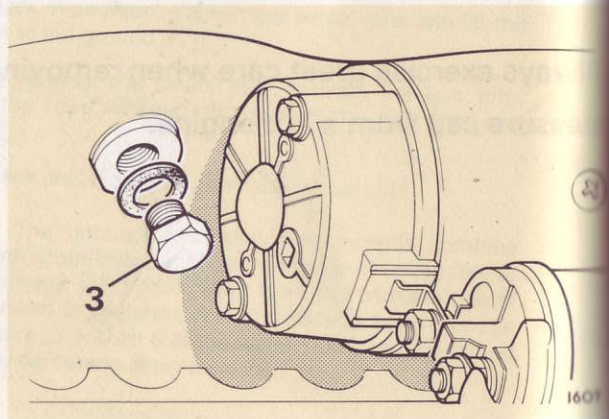
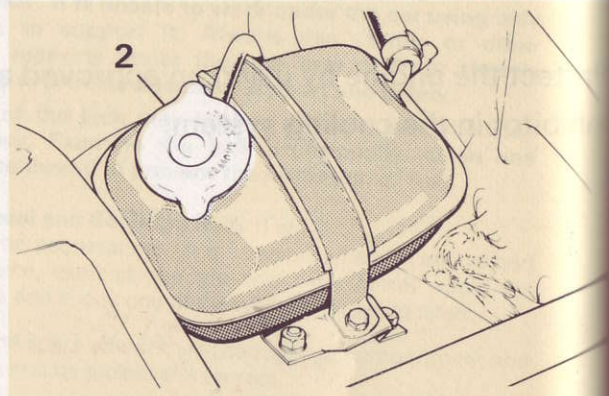
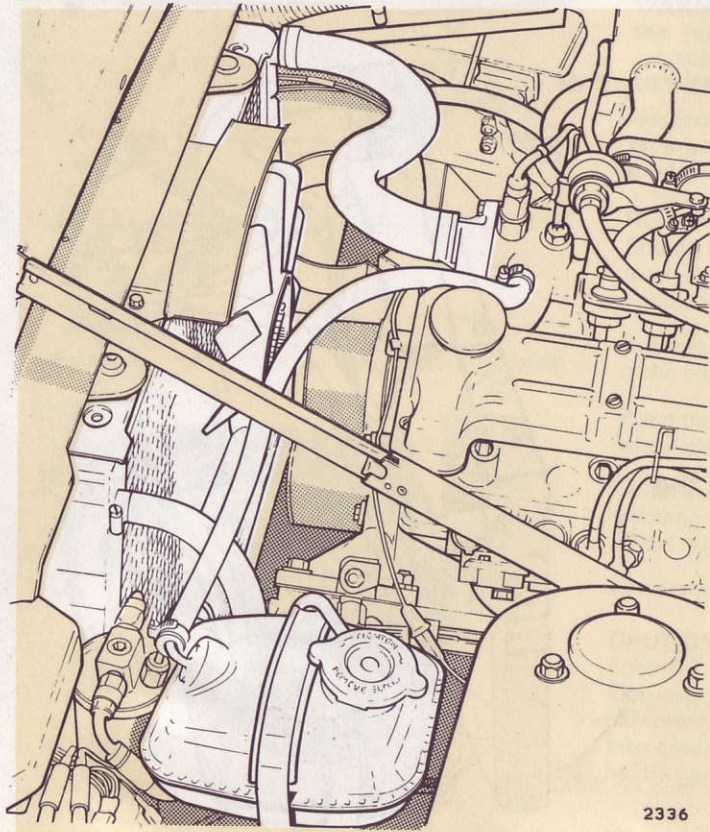

COOLING SYSTEM

Header Tank (1, Fig. 1)

The pressurised cooling system incorporates a header tank which provides a single point for coolant filling and level checking. The coolant level should be maintained 25mm (1in) below the neck of the header tank.

Pressure Cap (2, Fig. 1)

A pressure cap on the header tank permits a build up of pressure within the system as engine temperature increases enabling the system to operate at temperatures higher than the normal boiling point of coolant under atmospheric pressure.

It is extremely dangerous to remove the pressure cap when the engine is hot as the coolant will boil immediately when pressure is released.

WARNING: If it is necessary to remove the pressure cap when the engine is hot, exercise great care by protecting the hands against escaping steam. Slowly turn the pressure cap anti-clockwise until resistance of the safety stop is felt. Leave the cap in this position until all pressure is released. Press the cap downwards against the spring to clear the safety stops, and continue turning until it can be lifted off.

Draining (Fig. 1)

When the engine is cold, remove the pressure cap (2) and the cylinder block drain plug (3).

Slacken the bottom hose clip and disconnect the hose from the radiator.

Filling

Refit the bottom hose, ensuring that all hoses are in good condition and the hose connections are tight.

Refit the cylinder block drain plug (3).

Set the interior heater controls to the maximum heat position.

Remove the pressure cap (2) from the header tank (1), and fill the system until the coolant level is 25mm (1in.) below the neck of the header tank.

Refit the pressure cap and run the engine at approximately 1500 rev/min, until the temperature rises sufficiently to open the thermostat.

Stop the engine and carefully remove the pressure cap. Top up the coolant level in the header tank to within 25mm (1in.) of the neck of the tank, and refit the pressure cap.

COOLING SYSTEM

Frost Precautions

Water expands when it freezes, and if precautions are not taken there is considerable risk of bursting the radiator, cylinder block or heater. The heater unit cannot be drained with the cooling system; it is therefore essential to use anti-freeze in the cooling system in freezing conditions.

After filling with anti-freeze solution, attach a warning label in a prominent position on the car stating the type of anti-freeze contained in the cooling system to ensure that the correct type is used for topping-up.

Anti-freeze can remain in the cooling system for two years provided that the specific gravity of the coolant is checked

periodically and anti-freeze added as necessary. The specific gravity check should be carried out by an authorised Dealer. After the second year the system should be drained and flushed by inserting a hose in the filling orifice, removing the drain plugs, and allowing water to flow through until clean. Make sure that the cooling system is water-tight, examine all joints and replace any defective hoses. Refill with the appropriate anti-freeze solution.

The recommended quantities are given below.

Do not use radiator anti-freeze solution in the windscreen washing equipment. Use the correct washer solvent, which will not damage the paintwork.

Solution %	Amount of anti-freeze			Commences Freezing		Frozen Solid	
	Pts	U.S. pts	Litres	°C	°F	°C	°F
33 $\frac{1}{3}$	4.2	5.2	2.5	-19	-2	-36	-33
50	6.5	7.8	5.7	-36	-33	-48	-53

N.B. All quantities are approximate.

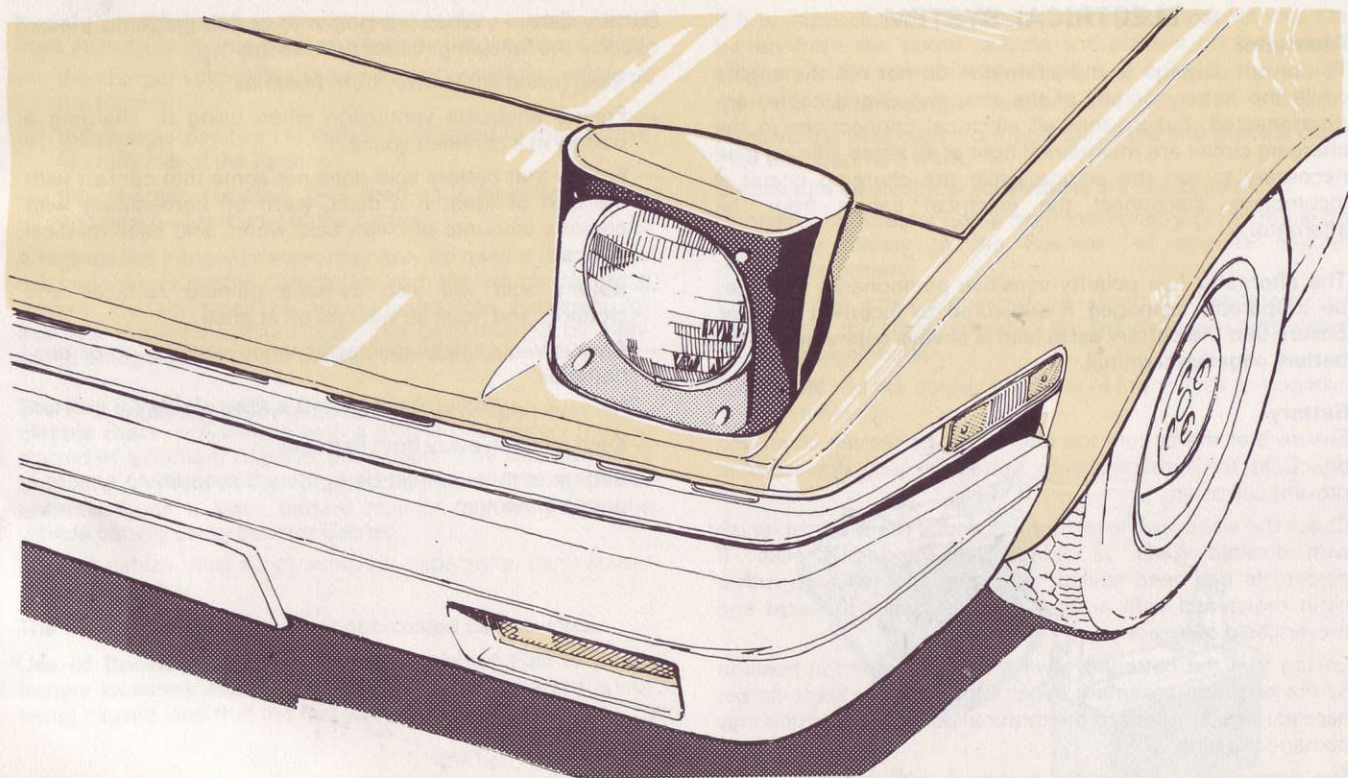

It is advisable to disconnect the battery when changing bulbs or fuses.

ELECTRICAL SYSTEM

ELECTRICAL SYSTEM

Alternator

To prevent damage to the alternator, do not run the engine while the battery or any of the charging circuit cables are disconnected. Ensure that all electrical connections in the charging circuit are maintained tight at all times. Should it be necessary to run the engine while the charging circuit is incomplete, disconnect the electrical cables from the alternator.

The alternator has polarity-sensitive components that may be irreparably damaged if subjected to incorrect polarity. Ensure that the battery earth lead is always connected to the battery negative terminal.

Battery

Ensure that the battery top and terminals remain clean and dry. Coat the terminals with petroleum jelly (Vaseline) to prevent corrosion.

Check the electrolyte level monthly and, if required, replenish with distilled water as detailed in 'Periodic Checks'. If electrolyte has been spilled, clean the affected area with a cloth moistened with ammonia to neutralize the acid and prevent acid corrosion.

Ensure that the battery is always firmly clamped in position by the retaining assembly. When fitting battery leads do not hammer the terminals to the terminal posts. Such action may damage the battery.

The battery will deteriorate rapidly if left in a discharged condition. If the unit is reduced to a low state of charge it should be recharged at the first opportunity.

Battery Care — When working with or near batteries please observe the following recommendations.

- Keep naked lights away from batteries.
- Ensure adequate ventilation when using or charging a battery in a confined space.
- Ensure that battery acid does not come into contact with the skin or eyes; If it does, wash off immediately with copious amounts of clean cold water, and seek medical advice.
- Battery acid will also damage painted surfaces and clothing, and must be washed off at once.
- Always wear safety spectacles when working on or near batteries.
- Remove rings, watches and other metal jewellery.
- Keep children away from batteries.
- Battery terminals must be tightened securely to ensure a good connection.

Battery Charging: When charging the battery in the vehicle from an outside source such as a trickle charger ensure that:

- the charger voltage is the same as the nominal voltage of the battery.
- the charger positive (+) lead is connected to the positive (+) terminal of the battery.
- the charger negative (—) lead is connected to the negative (—) terminal of the battery.

A high-speed battery charger may only be used if the battery has been disconnected completely from the vehicle electrical system. Certain types of maintenance free batteries, for example the lead calcium type, can be damaged by high-speed chargers. If in doubt consult your Dealer.

Starting a Vehicle with a Discharged Battery

Electric Start — A vehicle with a discharged battery may be started in a number of ways, the easiest is by substitution of the battery. Where this is not possible due to differing size or terminal types a slave battery may be connected to the vehicle battery using Booster Cables.

Booster cables must be of sufficient capacity to carry starter motor current.

The slave battery voltage must not exceed twelve volts.

Use of Booster Cables — Park the two vehicles with the battery locations adjacent, ensure that a road hazard is not being caused, and that the two vehicles do not touch.

If it is impossible to place the vehicles together remove the battery from the 'donor' vehicle and place it on the ground adjacent to the immobilised vehicle.

Carry out the following instructions.

Remove the vent caps from both batteries and place a cloth over the open vent wells.

Ensure that all electrical accessories are switched off.

Connect one Booster Cable from the Positive (+) terminal on the slave battery to the Positive (+) terminal of the discharged battery.

Connect the other Booster Cable from the Negative (—) terminal of the slave battery to the Negative (—) terminal of the discharged battery.

CAUTION: do not connect Positive (+) terminals to Negative (—) terminals.

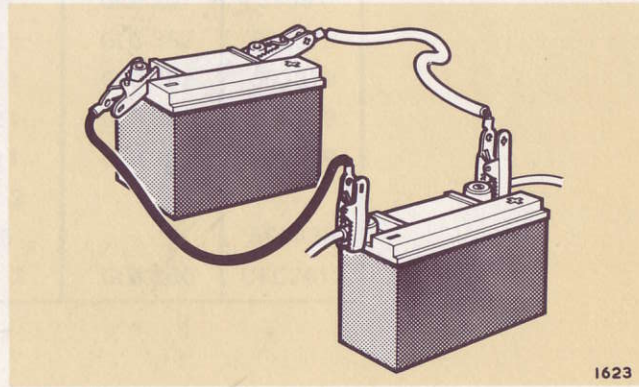

1623

ELECTRICAL SYSTEM

Where applicable, start the engine of the donor vehicle and let it idle for a few minutes, then start the engine of the vehicle with the discharged battery in the normal manner.

When the engine is running normally, disconnect the Booster Cables, first removing the cable from both + (Positive) terminals and then the one from both — (Negative) terminals. Ensure that no contact is made between either cables or the vehicles.

Remove the cloths covering the battery vent wells and dispose of them safely. Replace the vent caps.

The battery and charging system should be checked for condition by your Dealer.

If the Electric Start methods are not available then a Rolling Start may be employed on certain vehicles.

Rolling Start — A Rolling Start is pushing or towing the vehicle at low speed, in gear (preferably 2nd), with the clutch pedal depressed and the ignition switched on.

When sufficient speed is obtained, the clutch pedal is released and the traction force from the wheels starts the engine.

Rolling Starts cannot be employed on vehicles with Automatic Transmission, and **MUST NOT** be used on vehicles fitted with Catalytic Converters, as irreparable damage will be caused to the Converter.

WARNING: Because of the obvious dangers to other road users, extreme caution must be exercised when attempting a Rolling Start.

BULB CHART

Lamp	Watts	Unipart No.	Triumph Part No.
Headlamp R.H. Dip — U.S.A.	50/40		514578
Front parking lamp	4		
Front flasher lamp	21	GLB 382	502379
Front marker lamp	3	GLB 504	518414
Rear marker lamp	3	GLB 504	518414
Tail lamp	5	GLB 207	57591
Stop lamp	21	GLB 382	502379
Rear flasher lamp	21	GLB 382	502379
Reverse lamps	21	GLB 382	502379
Plate illumination lamp	21	GLB 382	502379
Instrument panel illumination	2-2		
Courtesy lamp	6		586438
Warning lights	1-2	GLB 286	UKC2412

ELECTRICAL SYSTEM

FUSE CHART

Fuse No.	Protected Circuits	Current Capacity
1 - 2	Fan relay (Air Conditioning)	20 amp
3 - 4	Heated rear window	15 amp
5 - 6	Horn relay, Cigar lighter, Hazard warning, Courtesy light, Fog light, Electric aerial (if fitted)	50 amp
7 - 8	Front right hand side light and side marker, Instrument lighting rheostat	15 amp
9 - 10	Front left hand side light and side marker	15 amp
11 - 12	Fan relay (Air conditioning)	20 amp
13 - 14	Left hand headlamp dipped beam	25 amp
15 - 16	Windscreen wiper motor, Reverse light	25 amp
17 - 18	Left hand headlamp main beam	25 amp
19 - 20	Compressor clutch relay (Air conditioning), Blower fans	35 amp
21 - 22	Right hand headlamp main beam	25 amp
23 - 24	Right hand headlamp dipped beam	25 amp

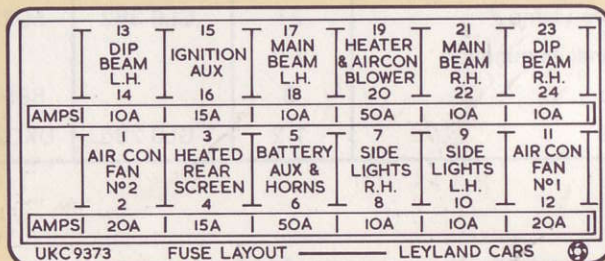

1622

Fig. 1

Fuses (Fig. 1)

A fusebox is mounted on a relay plate and is accessible after removal of the cover panel at the front-end of the glovebox. The unit contains twelve operational fuses and has provision for four spare fuses in the pull-off cover.

Failure of a particular fuse is indicated when all circuits protected by it become inoperative. Before renewing a blown fuse inspect the wiring of the circuits that have failed for evidence of a short-circuit or other fault. If a new fuse blows immediately and the cause of the trouble cannot be found have the circuit checked by your Jaguar-Rover-Triumph Dealer.

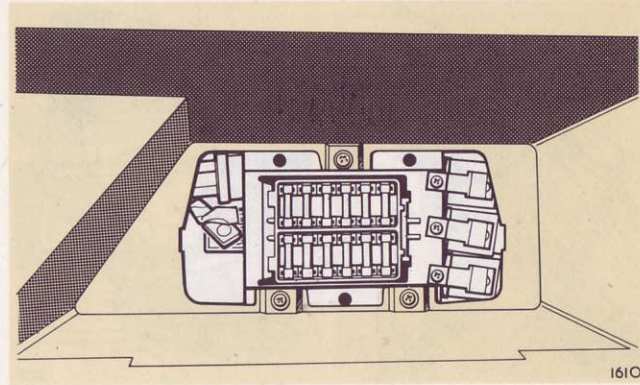

ELECTRICAL SYSTEM

Fig. 2

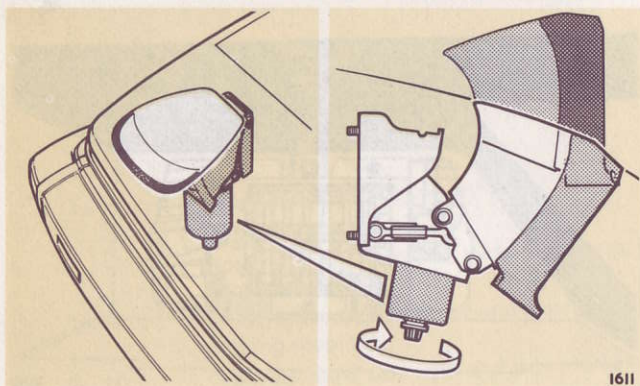
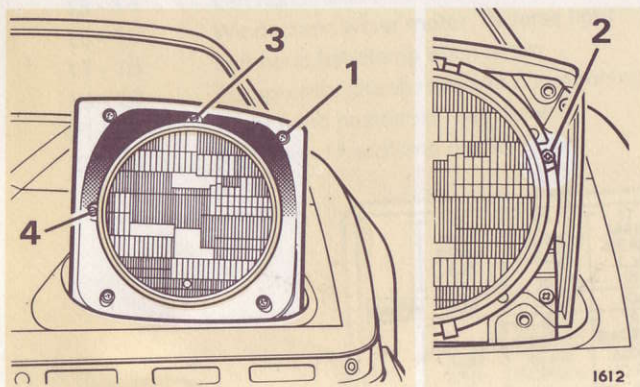

Fig. 3



Headlamps (Fig. 2 - Fig. 3)

In the event of electrical failure, the headlamps can be raised manually as follows: disconnect the plug in the engine bay (refer to underbonnet label), and locate the knob situated below the headlamp motor and turn it in the direction indicated in the illustration, until the headlamp is fully raised. To lower, continue to turn the knob in the same direction until the headlamp is lowered.

Filament failure — Raise the affected headlamp manually. Take out four screws (1) and remove the cowl.

Remove three screws (2) to release the retaining rim and light unit. Pull the connector from the light unit or bulb. Renew faulty item and reassemble.

Beam Aiming — Adjust screw (3) to move the beam in a vertical plane; adjust screw (4) to move the beam in a horizontal plane.

To comply with legal requirements, beam checking and resetting should be entrusted to a Jaguar-Rover-Triumph Dealer who has special equipment for this purpose.

Fig. 4

Front Parking and Direction Indicator Lamps (1, Fig. 4)

Remove two screws and withdraw the lamp lens to gain access to the parking bulb and direction indicator bulb.

Rear Direction Indicator, Stop/Park and Reverse Lamps. (2, Fig. 4)

Open the luggage compartment lid. Remove the screws and turn back the trim panel to gain access to the lamp cluster.

Twist the appropriate bulb holder from the lamp cluster. Renew the bulb and re-assemble.

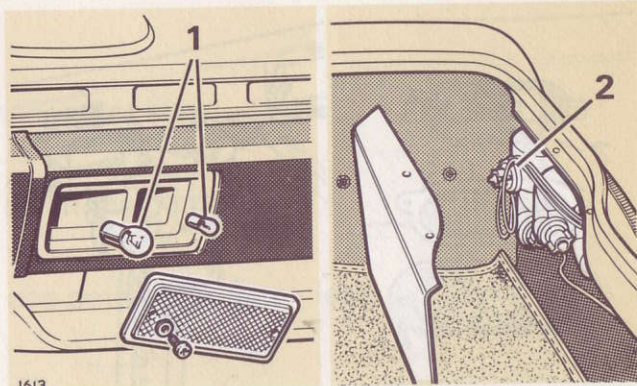

1613

Fig. 5

Side Marker Lamps (Fig. 5)

Unscrew the two nuts and washers, detach the cover and pull out the bulbholder. Renew the bulb and re-assemble.

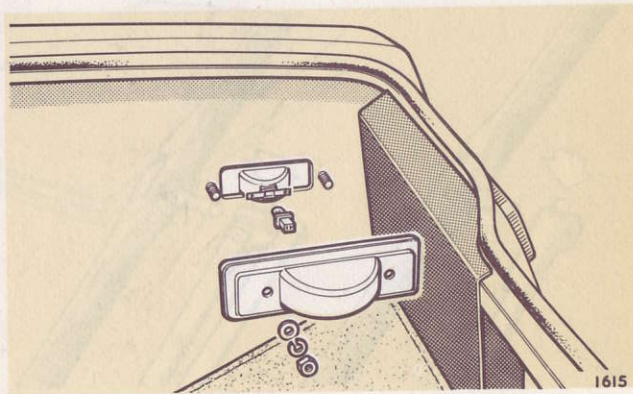

1615

ELECTRICAL SYSTEM

Fig. 6

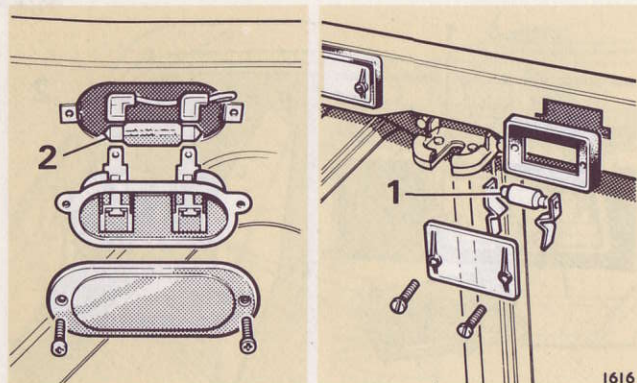

Fig. 7

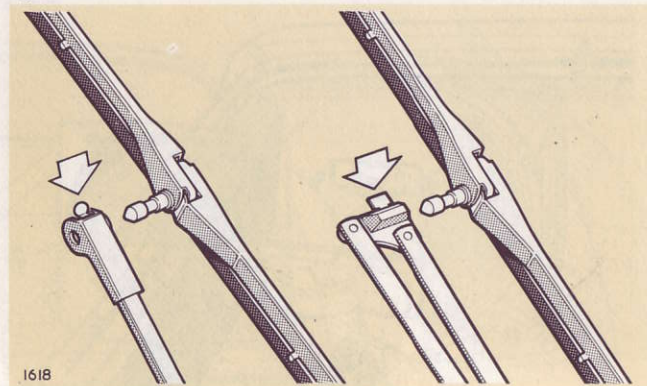

Plate Illumination Lamp (1, Fig. 6)

Remove two screws and detach the cover to gain access to the bulb(s).

Luggage Compartment Lamp (2, Fig. 6)

Take out two screws and withdraw the lamp and lens from the panel. Replace the bulb and re-assemble.

Door Lamps

Disconnect the battery. Prise out the lamp from one end and replace the bulb.

Refit the lamp by engaging the locating clips and pushing the lamp into position.

Windscreen Wipers (Fig. 7)

Service position of driver's wiper arm and blade — Wet the windscreen. Switch on ignition and wipers. Stop the wiper assembly in a vertical position by switching off the ignition at an appropriate moment. Lift the wiper arm and blade from the screen so that it falls into its service position.

Do not switch on the ignition until the arm is returned to its normal position on the screen. If this is done the pantograph arm will jam, the motor will stall and the appropriate fuse will 'blow' to prevent damage to the arm or motor.

Renew driver's wiper blade — Depress the clip and withdraw the wiper blade from the pivot block.

Renew passenger's wiper blade — Depress the clip and withdraw the wiper blade from the arm.

DO NOT wash or polish the car under a hot sun.

DO NOT use petrol to clean the bumpers.

DO NOT use petrol/spirits to clean the wheel trims.



1823

CARE OF BODYWORK

CARE OF BODYWORK

Washing

Avoid using a dry cloth to wipe dust from the paintwork and chromium surfaces. Dust is an abrasive and if removed in this way it will scratch the polished surfaces. Wash the car frequently with plenty of running water and a clean, soft sponge. Soften, and if possible remove the mud with water before using the sponge. When all dirt is removed, sponge off and dry with a clean, damp chamois-leather. Never wash or polish the car under a hot sun.

Removing Grease and Tar

Remove grease or tar with methylated spirits (alcohol). White spirit is also effective, but this must not be applied to rubber, particularly the windscreen wiper blades.

Glass Surfaces

Glass is easily scratched. This can be avoided by always using a damp chamois-leather which is especially reserved for use on glass only. If silicone polishes have been used on the body, take care that the polish does not come into contact with the glass. It is extremely difficult to remove and causes the windscreen to smear.

Chromium Plating and Stainless Steel

Frequent washing and thorough drying is recommended, especially during the winter months when there is likelihood of corrosion through contamination with road salt.

Polishing

After a period of use, the formation of traffic film will cause the paintwork to lose some of its lustre, even though the car has been carefully and regularly washed. The original brilliance may be restored after washing by using a reputable non-abrasive cleaner and polish.

Being the most durable, wax preparations are preferable, but where these are used regularly the old wax must first be removed with a cleaner before further application of new wax. The frequency at which polishing is necessary will depend upon local conditions of air pollution.

Interior

Brush and clean the inside of your car each time you wash and polish the outside. Use a vacuum cleaner where possible and ensure complete removal of all dust from the interior and trim.

Wash the upholstery with luke-warm, non-caustic, soapy water. Do not use detergents or household cleaners as these may cause damage.

Remove all traces of suds with a clean, damp cloth and thoroughly dry the upholstery with a dry duster or towel.

Wipe the fascia and instrument panel with a damp cloth only. Wax or other polishes should not be used inside the car.

Opening Roof

Periodically, clean the sliding roof side rail rebate and, if sticking or jamming occurs, lubricate very sparingly using a silicone base aerosol penetrating fluid.

Inflammability

The car interior conforms to State and Federal laws on flammability. To preserve this condition do not clean interior other than as described above.

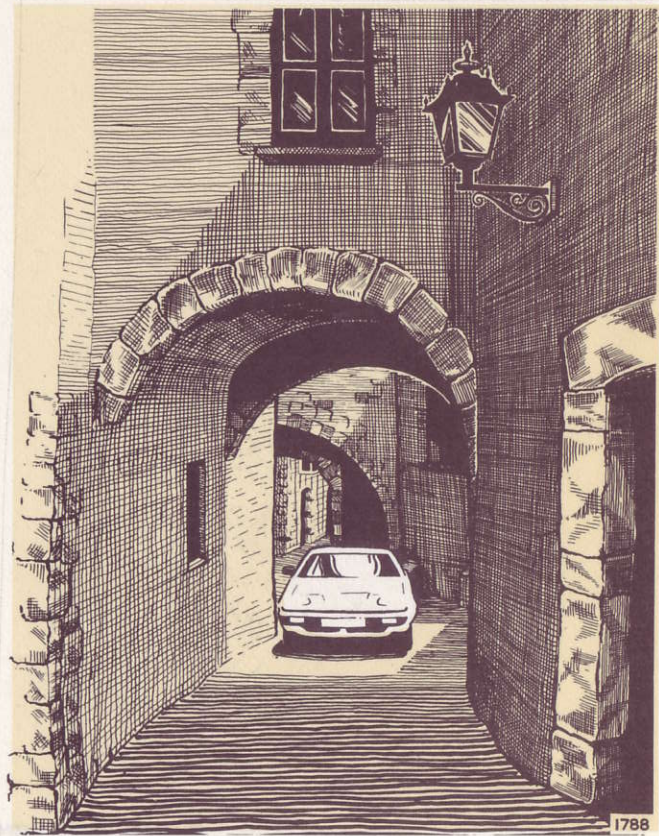



Publication Part No. AKM 4152